



**Anevas Technologies,
Incorporated**

**Anevas Tech. Portable Medical Bench
Final CAD Package**

Team Members:

Hunter Daniel
Katherine Riffle
Kenyon Rowley

Client:

Dr. Timothy Becker

2

1

B

B

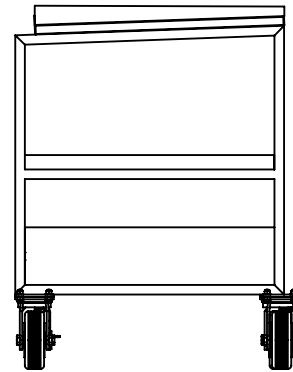
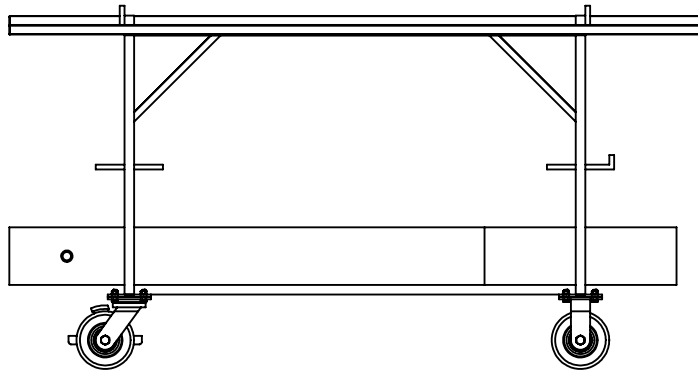
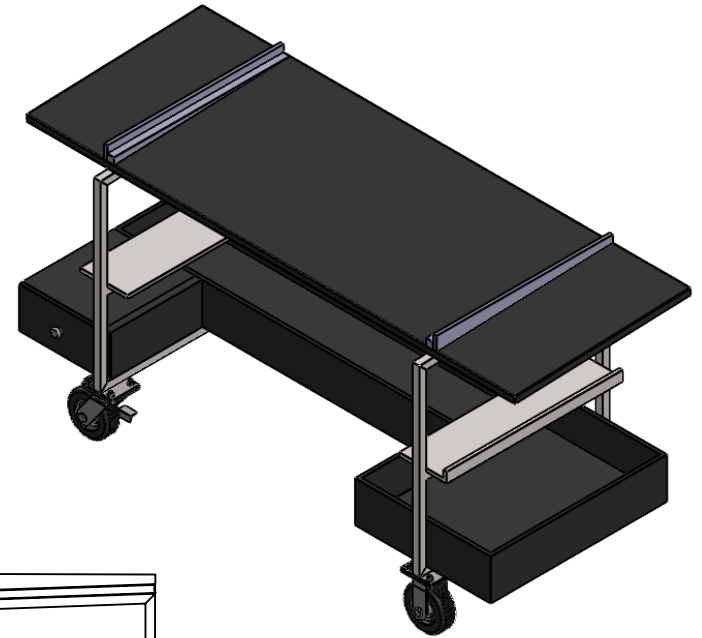
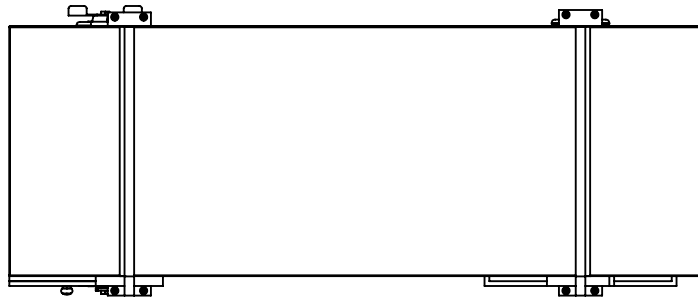

A

A

PROPRIETARY AND CONFIDENTIAL
 THE INFORMATION CONTAINED IN THIS DRAWING IS THE SOLE PROPERTY OF <INSERT COMPANY NAME HERE>. ANY REPRODUCTION IN PART OR AS A WHOLE WITHOUT THE WRITTEN PERMISSION OF <INSERT COMPANY NAME HERE> IS PROHIBITED.

		UNLESS OTHERWISE SPECIFIED:		NAME	DATE
		DIMENSIONS ARE IN INCHES	DRAWN	Kenyon	
		TOLERANCES:	CHECKED		
		FRACTIONAL ±	ENG APPR.		
		ANGULAR: MACH ± BEND ±	MFG APPR.		
		TWO PLACE DECIMAL ±	Q.A.		
		THREE PLACE DECIMAL ±	COMMENTS:		
		INTERPRET GEOMETRIC TOLERANCING PER:			
		MATERIAL			
NEXT ASSY	USED ON	FINISH			
APPLICATION		DO NOT SCALE DRAWING			

TITLE:
Port_Bench_ASM

SIZE	DWG. NO.	REV
A	Port_Bench_ASM	

SCALE: 1:20 WEIGHT: SHEET 2 OF 22

2

1

B

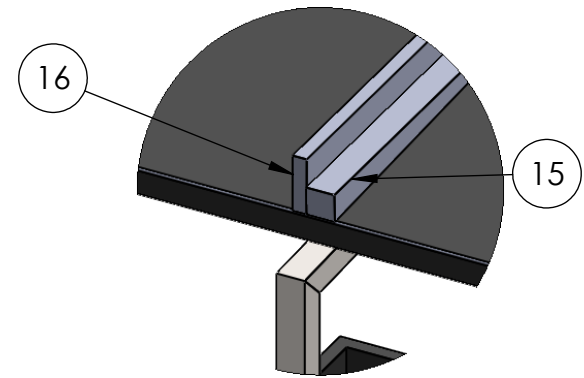
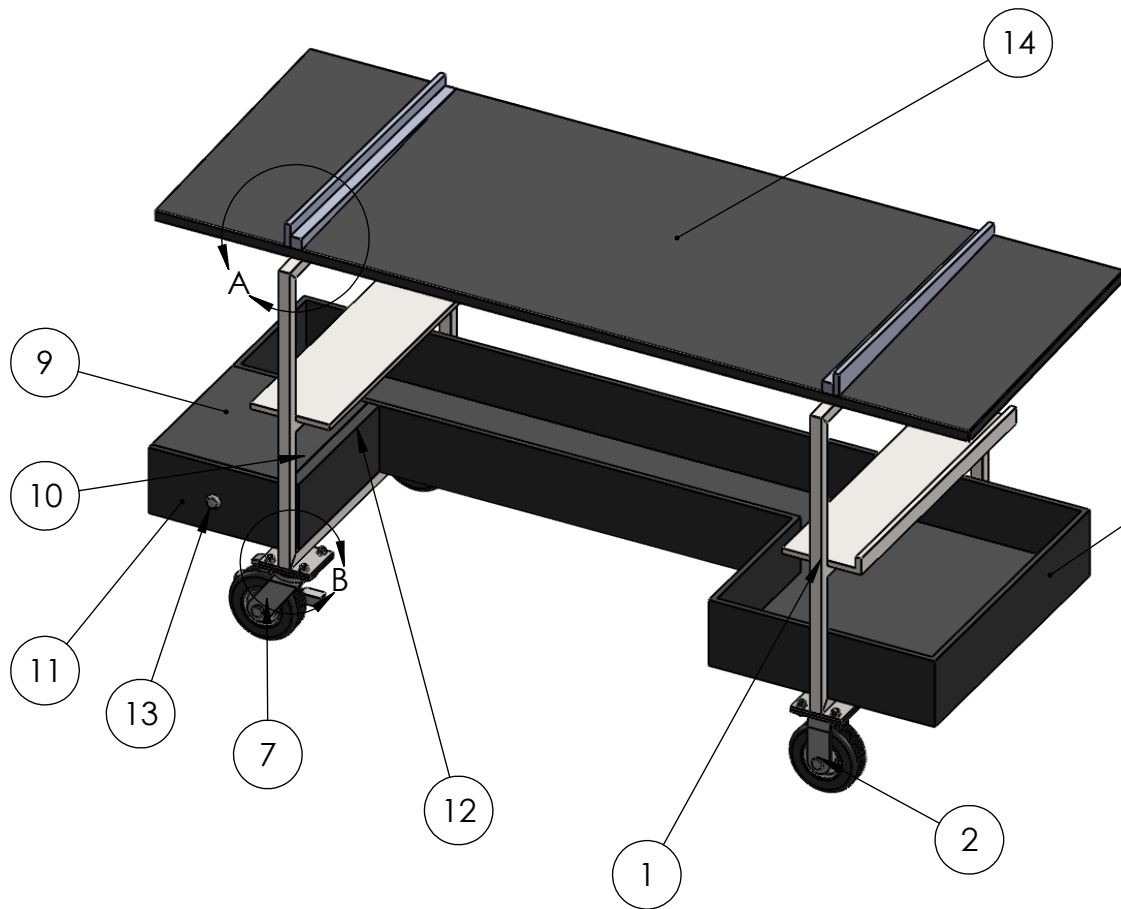

DETAIL A
SCALE 1 : 6

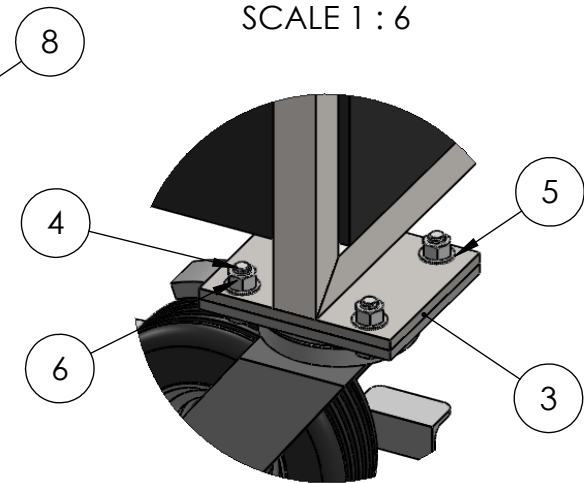

DETAIL B
SCALE 1 : 4

B

A

A

PROPRIETARY AND CONFIDENTIAL
THE INFORMATION CONTAINED IN THIS DRAWING IS THE SOLE PROPERTY OF <INSERT COMPANY NAME HERE>. ANY REPRODUCTION IN PART OR AS A WHOLE WITHOUT THE WRITTEN PERMISSION OF <INSERT COMPANY NAME HERE> IS PROHIBITED.

		UNLESS OTHERWISE SPECIFIED:		NAME	DATE	TITLE: Port_Bench_ASM		
		DIMENSIONS ARE IN INCHES	DRAWN	Kenyon				
		TOLERANCES:	CHECKED					
		FRACTIONAL \pm	ENG APPR.					
		ANGULAR: MACH \pm BEND \pm	MFG APPR.					
		TWO PLACE DECIMAL \pm	Q.A.			SIZE	DWG. NO.	REV
		THREE PLACE DECIMAL \pm	COMMENTS:			A	Port_Bench_BOM	
		INTERPRET GEOMETRIC TOLERANCING PER:				SCALE: 1:20	WEIGHT:	SHEET 3 OF 22
		MATERIAL						
		FINISH						
	NEXT ASSY	USED ON						
	APPLICATION							
		DO NOT SCALE DRAWING						

2

1

2

1

B

B

ITEM NO.	PART NUMBER	DESCRIPTION	QTY.
1	Frame	Frame	1
2	22925T77	Caster	2
3	Bolt_Plate	Bolt Plate	4
4	91309A624	Bolt	16
5	90107A127	Washer	16
6	90490A031	Nut	16
7	22925T76	Caster Locking	2
8	Storage_Main	Storage Main	1
9	Drawer_Housing	Drawer Housing	1
10	Drawer_Main	Drawer Main	1
11	Front_Plate	Drawer Front Plate	1
12	Drawer_Support	Drawer Support	1
13	11705A13	Drawer Knob	1
14	Tabletop	Tabletop	1
15	Wedge	Wedge	2
16	Wedge_Groove	Wedge Groove	2

A

A

PROPRIETARY AND CONFIDENTIAL
 THE INFORMATION CONTAINED IN THIS DRAWING IS THE SOLE PROPERTY OF <INSERT COMPANY NAME HERE>. ANY REPRODUCTION IN PART OR AS A WHOLE WITHOUT THE WRITTEN PERMISSION OF <INSERT COMPANY NAME HERE> IS PROHIBITED.

		UNLESS OTHERWISE SPECIFIED:	NAME	DATE	TITLE: Port_Bench_ASM
		DIMENSIONS ARE IN INCHES	DRAWN	Kenyon	
		TOLERANCES: FRACTIONAL ±	CHECKED		
		ANGULAR: MACH ± BEND ±	ENG APPR.		
		TWO PLACE DECIMAL ±	MFG APPR.		
		THREE PLACE DECIMAL ±	Q.A.		
		INTERPRET GEOMETRIC TOLERANCING PER:	COMMENTS:		SIZE
NEXT ASSY	USED ON	MATERIAL			DWG. NO.
		FINISH			A Port_Bench_BOM
APPLICATION		DO NOT SCALE DRAWING			REV
					SCALE: 1:20
					WEIGHT:
					SHEET 4 OF 22

2

1

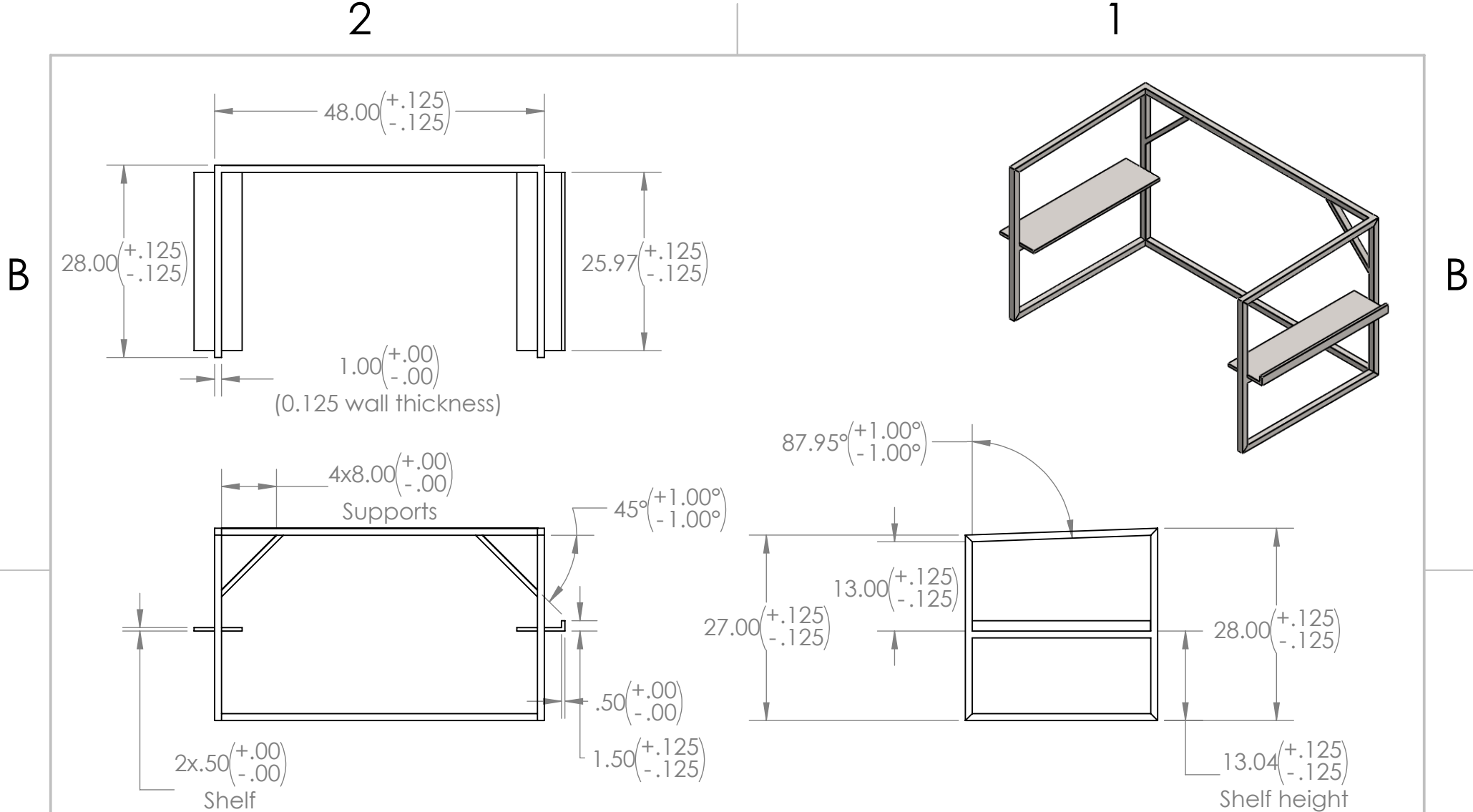

A

A

PROPRIETARY AND CONFIDENTIAL
 THE INFORMATION CONTAINED IN THIS DRAWING IS THE SOLE PROPERTY OF <INSERT COMPANY NAME HERE>. ANY REPRODUCTION IN PART OR AS A WHOLE WITHOUT THE WRITTEN PERMISSION OF <INSERT COMPANY NAME HERE> IS PROHIBITED.

		UNLESS OTHERWISE SPECIFIED:		NAME	DATE
		DIMENSIONS ARE IN INCHES	DRAWN	Kenyon	
		TOLERANCES:	CHECKED		
		FRACTIONAL: \pm	ENG APPR.		
		ANGULAR: MACH \pm BEND \pm	MFG APPR.		
		TWO PLACE DECIMAL \pm	Q.A.		
		THREE PLACE DECIMAL \pm	COMMENTS:		
		INTERPRET GEOMETRIC TOLERANCING PER:			
		MATERIAL			
		Mild Steel			
		FINISH			
NEXT ASSY	USED ON				
APPLICATION		DO NOT SCALE DRAWING			

TITLE:		
Frame_ASM		
SIZE	DWG. NO.	REV
A	Frame	
SCALE: 1:20		WEIGHT:
		SHEET 5 OF 22

2

1

2

1

B

B

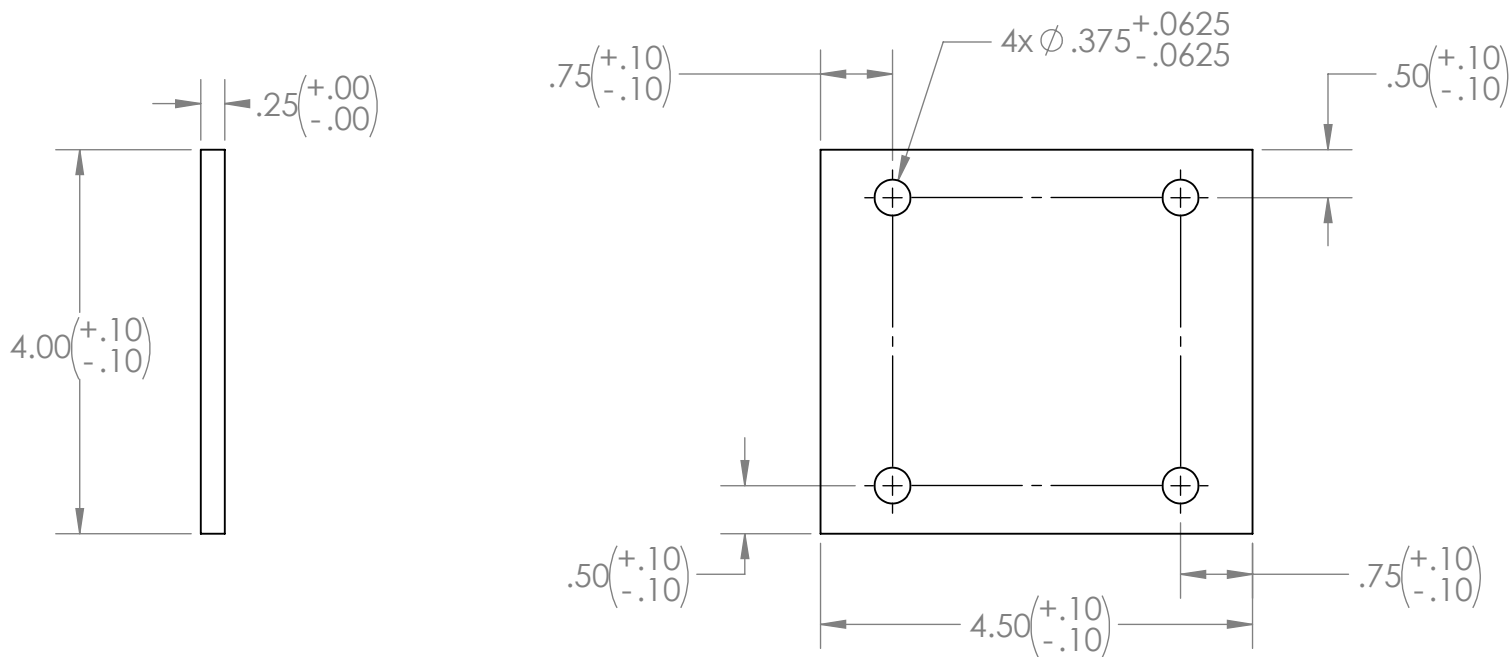
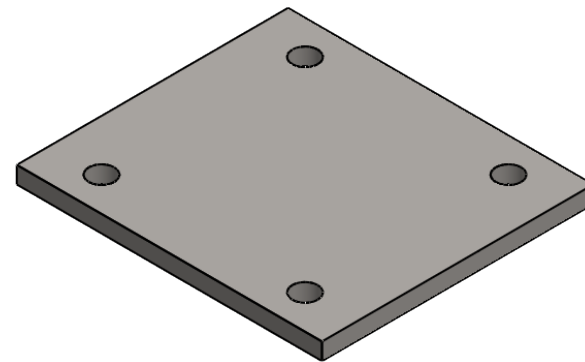

A

A

PROPRIETARY AND CONFIDENTIAL
 THE INFORMATION CONTAINED IN THIS DRAWING IS THE SOLE PROPERTY OF <INSERT COMPANY NAME HERE>. ANY REPRODUCTION IN PART OR AS A WHOLE WITHOUT THE WRITTEN PERMISSION OF <INSERT COMPANY NAME HERE> IS PROHIBITED.

		UNLESS OTHERWISE SPECIFIED:		NAME	DATE	TITLE: Frame_ASM							
		DIMENSIONS ARE IN INCHES	DRAWN	Kenyon				SIZE	DWG. NO.	REV			
		TOLERANCES: FRACTIONAL ±	CHECKED								A	Bolt_Plate	
		ANGULAR: MACH ± BEND ±	ENG APPR.					SCALE: 1:2	WEIGHT:	SHEET 6 OF 22			
		TWO PLACE DECIMAL ±	MFG APPR.										
		THREE PLACE DECIMAL ±	Q.A.										
		INTERPRET GEOMETRIC TOLERANCING PER:	COMMENTS:										
		MATERIAL Mild Steel											
		FINISH											
	NEXT ASSY	USED ON											
	APPLICATION		DO NOT SCALE DRAWING										

2

1

2

1

B

B

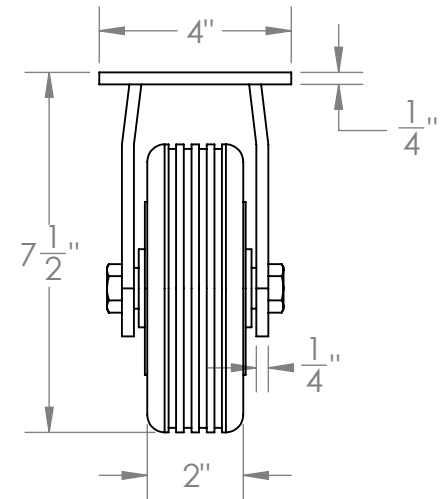
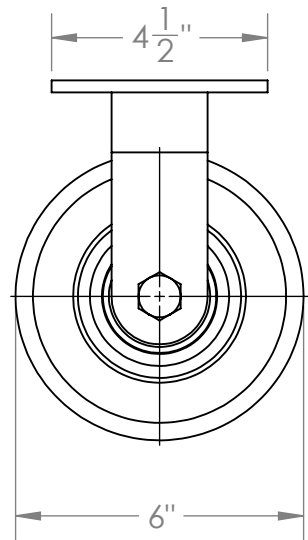
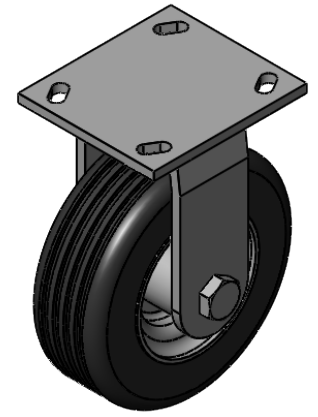
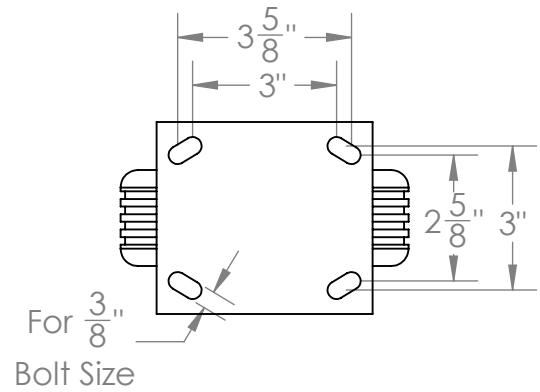

A

A

PROPRIETARY AND CONFIDENTIAL
 THE INFORMATION CONTAINED IN THIS DRAWING IS THE SOLE PROPERTY OF <INSERT COMPANY NAME HERE>. ANY REPRODUCTION IN PART OR AS A WHOLE WITHOUT THE WRITTEN PERMISSION OF <INSERT COMPANY NAME HERE> IS PROHIBITED.

		UNLESS OTHERWISE SPECIFIED:	NAME	DATE
		DIMENSIONS ARE IN INCHES	DRAWN	Kenyon
		TOLERANCES:	CHECKED	
		FRACTIONAL ±	ENG APPR.	
		ANGULAR: MACH ± BEND ±	MFG APPR.	
		TWO PLACE DECIMAL ±	Q.A.	
		THREE PLACE DECIMAL ±	COMMENTS:	
		INTERPRET GEOMETRIC TOLERANCING PER:	Part from McMaster-Carr	
		MATERIAL		
		FINISH		
NEXT ASSY	USED ON	APPLICATION	SCALE: 1:5	WEIGHT:
		DO NOT SCALE DRAWING	SHEET 7 OF 22	

TITLE:		
Frame_ASM		
SIZE	DWG. NO.	REV
A	Caster	
SCALE: 1:5 WEIGHT: SHEET 7 OF 22		

2

1

B

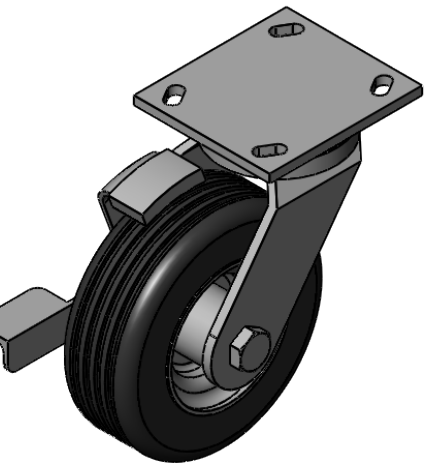
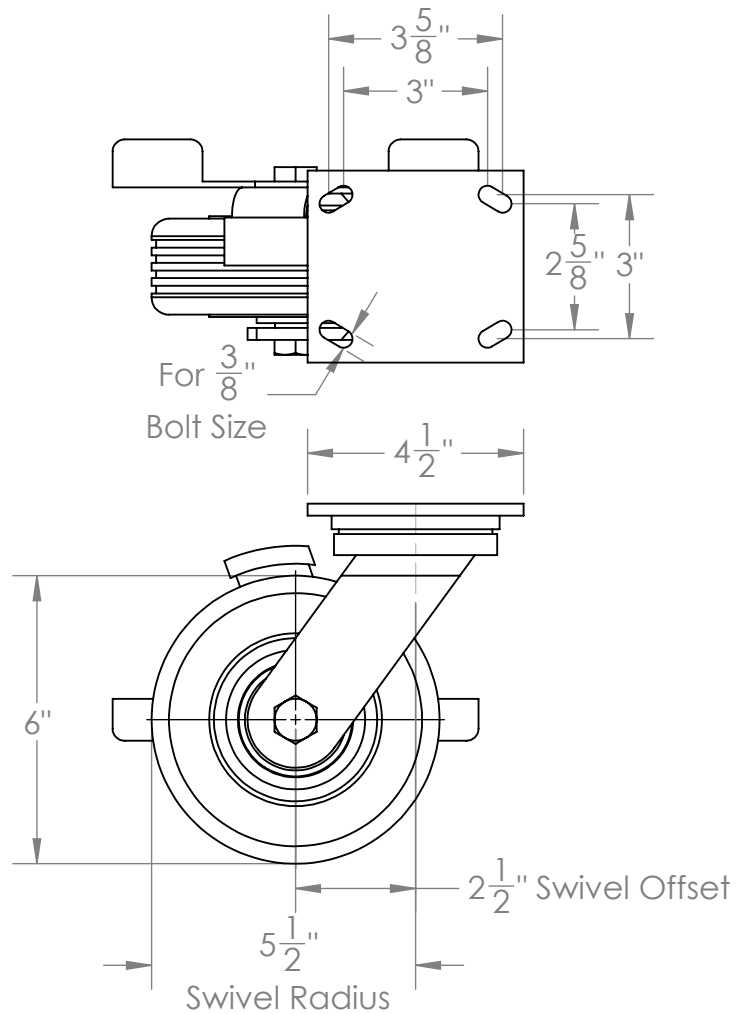

B

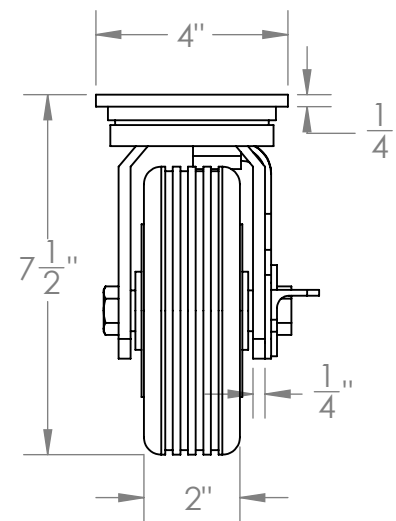

A

PROPRIETARY AND CONFIDENTIAL
 THE INFORMATION CONTAINED IN THIS DRAWING IS THE SOLE PROPERTY OF <INSERT COMPANY NAME HERE>. ANY REPRODUCTION IN PART OR AS A WHOLE WITHOUT THE WRITTEN PERMISSION OF <INSERT COMPANY NAME HERE> IS PROHIBITED.

		UNLESS OTHERWISE SPECIFIED:		NAME	DATE	TITLE: Frame_ASM			
		DIMENSIONS ARE IN INCHES	DRAWN	Kenyon					
		TOLERANCES:	CHECKED						
		FRACTIONAL \pm	ENG APPR.						
		ANGULAR: MACH \pm BEND \pm	MFG APPR.						
		TWO PLACE DECIMAL \pm	Q.A.			SIZE	DWG. NO.	REV	
		THREE PLACE DECIMAL \pm	COMMENTS:	Part from McMaster-Carr.			A	Caster_Locking	
		INTERPRET GEOMETRIC TOLERANCING PER:				SCALE: 1:5	WEIGHT:	SHEET 8 OF 22	
		MATERIAL							
		FINISH							
	NEXT ASSY	USED ON							
	APPLICATION		DO NOT SCALE DRAWING						

2

1

2

1

B

B

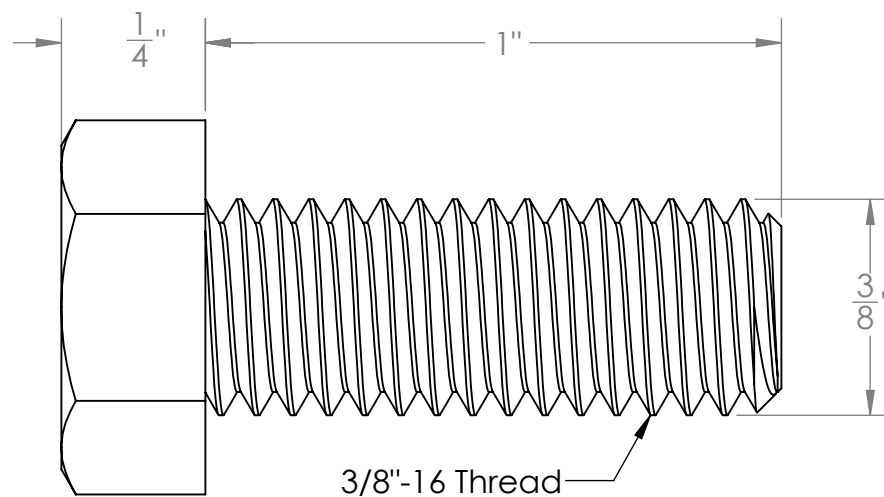
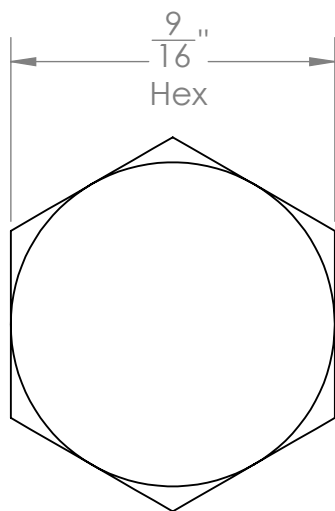
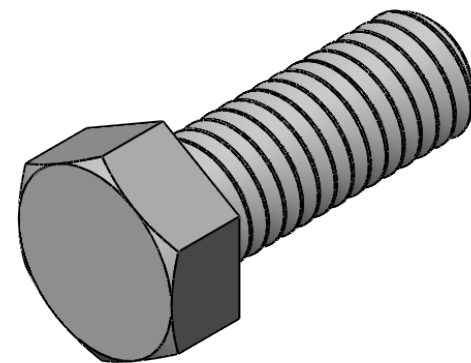

A

A

PROPRIETARY AND CONFIDENTIAL
 THE INFORMATION CONTAINED IN THIS DRAWING IS THE SOLE PROPERTY OF <INSERT COMPANY NAME HERE>. ANY REPRODUCTION IN PART OR AS A WHOLE WITHOUT THE WRITTEN PERMISSION OF <INSERT COMPANY NAME HERE> IS PROHIBITED.

		UNLESS OTHERWISE SPECIFIED:		NAME	DATE
		DIMENSIONS ARE IN INCHES	DRAWN	Kenyon	
		TOLERANCES:	CHECKED		
		FRACTIONAL ±	ENG APPR.		
		ANGULAR: MACH ± BEND ±	MFG APPR.		
		TWO PLACE DECIMAL ±	Q.A.		
		THREE PLACE DECIMAL ±	COMMENTS:		
		INTERPRET GEOMETRIC TOLERANCING PER:	Part from McMaster-Carr		
		MATERIAL			
		Steel			
		FINISH			
		Zinc Plated			
NEXT ASSY	USED ON	APPLICATION			
		DO NOT SCALE DRAWING			

TITLE:		
Frame_ASM		
SIZE	DWG. NO.	REV
A	Bolt	
SCALE: 2:1	WEIGHT:	SHEET 9 OF 22

2

1

2

1

B

B

3/8"- 16 Thread

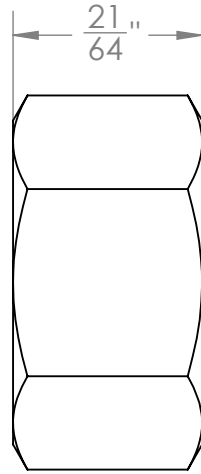
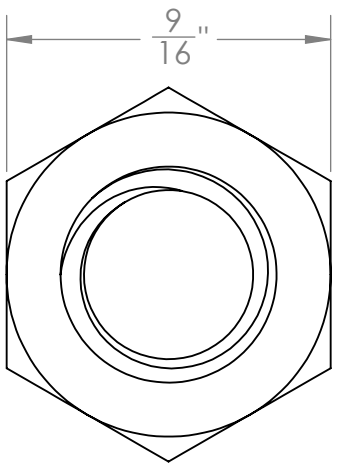
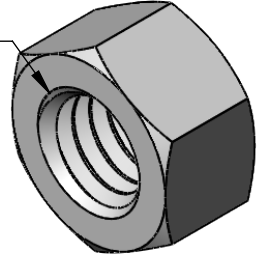

A

A

PROPRIETARY AND CONFIDENTIAL
 THE INFORMATION CONTAINED IN THIS DRAWING IS THE SOLE PROPERTY OF <INSERT COMPANY NAME HERE>. ANY REPRODUCTION IN PART OR AS A WHOLE WITHOUT THE WRITTEN PERMISSION OF <INSERT COMPANY NAME HERE> IS PROHIBITED.

		UNLESS OTHERWISE SPECIFIED:		NAME	DATE
		DIMENSIONS ARE IN INCHES	DRAWN	Kenyon	
		TOLERANCES:	CHECKED		
		FRACTIONAL ±	ENG APPR.		
		ANGULAR: MACH ± BEND ±	MFG APPR.		
		TWO PLACE DECIMAL ±	Q.A.		
		THREE PLACE DECIMAL ±	COMMENTS:		
		INTERPRET GEOMETRIC TOLERANCING PER:	Part from McMaster-Carr		
		MATERIAL	Steel		
NEXT ASSY	USED ON	FINISH			
APPLICATION		DO NOT SCALE DRAWING			

TITLE:		
Frame_ASM		
SIZE	DWG. NO.	REV
A	Nut	
SCALE: 2:1	WEIGHT:	SHEET 10 OF 22

2

1

2

1

B

B

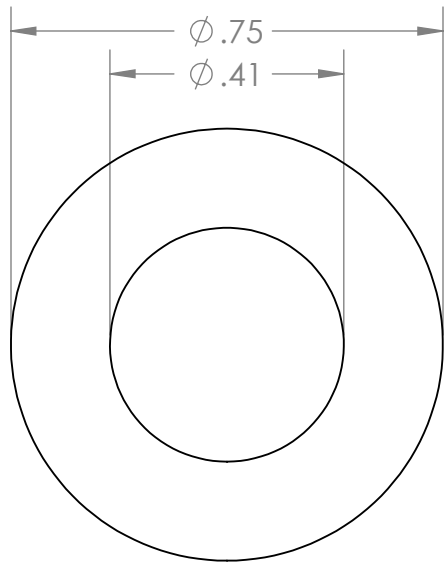

For 3/8" Screw Size

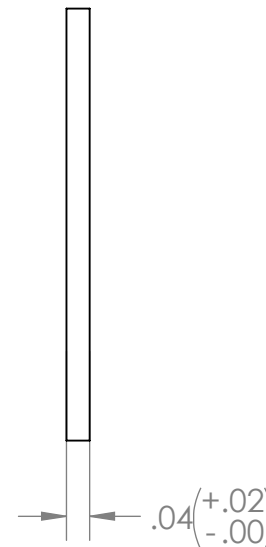
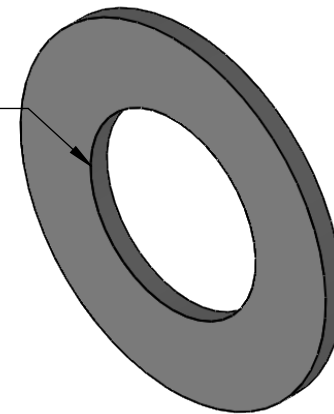

A

A

PROPRIETARY AND CONFIDENTIAL
 THE INFORMATION CONTAINED IN THIS DRAWING IS THE SOLE PROPERTY OF <INSERT COMPANY NAME HERE>. ANY REPRODUCTION IN PART OR AS A WHOLE WITHOUT THE WRITTEN PERMISSION OF <INSERT COMPANY NAME HERE> IS PROHIBITED.

		UNLESS OTHERWISE SPECIFIED:		NAME	DATE
		DIMENSIONS ARE IN INCHES	DRAWN	Kenyon	
		TOLERANCES:	CHECKED		
		FRACTIONAL \pm	ENG APPR.		
		ANGULAR: MACH \pm BEND \pm	MFG APPR.		
		TWO PLACE DECIMAL \pm	Q.A.		
		THREE PLACE DECIMAL \pm	COMMENTS:		
		INTERPRET GEOMETRIC TOLERANCING PER:	Part from McMaster-Carr.		
		MATERIAL	Stainless Steel		
NEXT ASSY	USED ON	FINISH			
APPLICATION		DO NOT SCALE DRAWING			

TITLE:		
Frame_ASM		
SIZE	DWG. NO.	REV
A	Washer	
SCALE: 5:1	WEIGHT:	SHEET 11 OF 22

2

1

2

1

B

B

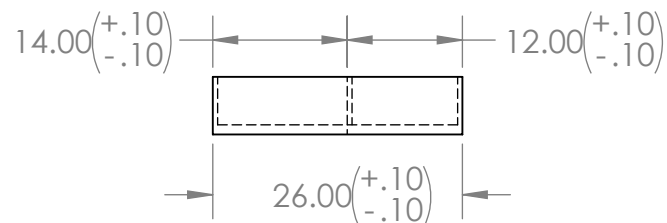
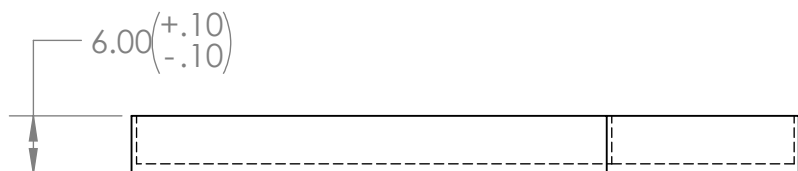
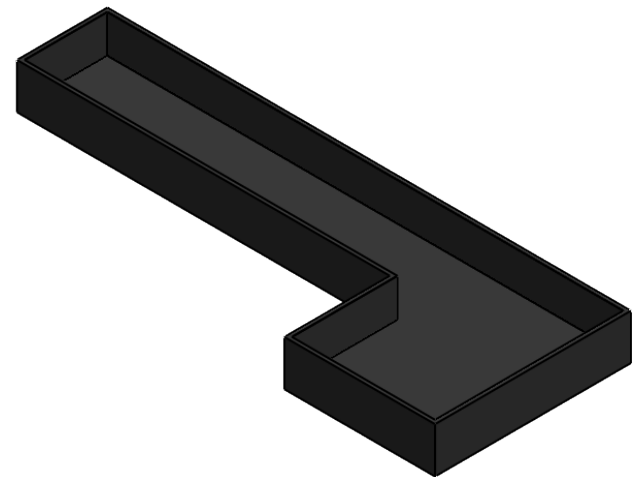
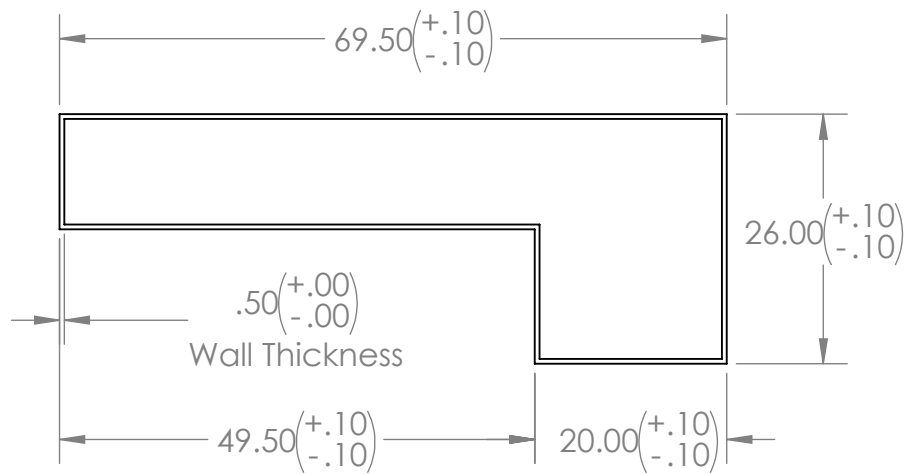

A

A

PROPRIETARY AND CONFIDENTIAL
 THE INFORMATION CONTAINED IN THIS DRAWING IS THE SOLE PROPERTY OF <INSERT COMPANY NAME HERE>. ANY REPRODUCTION IN PART OR AS A WHOLE WITHOUT THE WRITTEN PERMISSION OF <INSERT COMPANY NAME HERE> IS PROHIBITED.

		UNLESS OTHERWISE SPECIFIED:		NAME	DATE
		DIMENSIONS ARE IN INCHES	DRAWN	Kenyon	
		TOLERANCES:	CHECKED		
		FRACTIONAL ±	ENG APPR.		
		ANGULAR: MACH ± BEND ±	MFG APPR.		
		TWO PLACE DECIMAL ±	Q.A.		
		THREE PLACE DECIMAL ±	COMMENTS:		
		INTERPRET GEOMETRIC TOLERANCING PER:			
		MATERIAL			
		BC Plywood			
		FINISH			
NEXT ASSY	USED ON				
APPLICATION		DO NOT SCALE DRAWING			

TITLE:		
Storage_ASM		
SIZE	DWG. NO.	REV
A	Storage_Main	
SCALE: 1:20	WEIGHT:	SHEET 12 OF 22

2

1

B

B

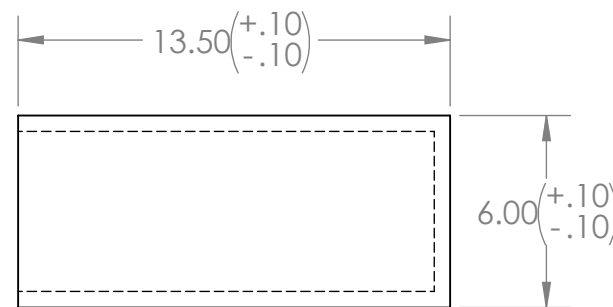
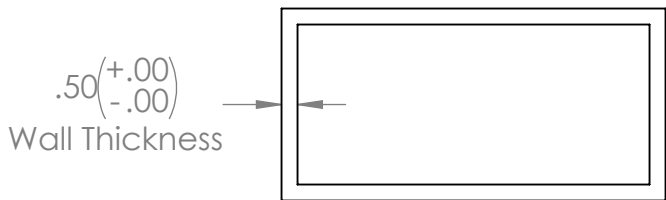
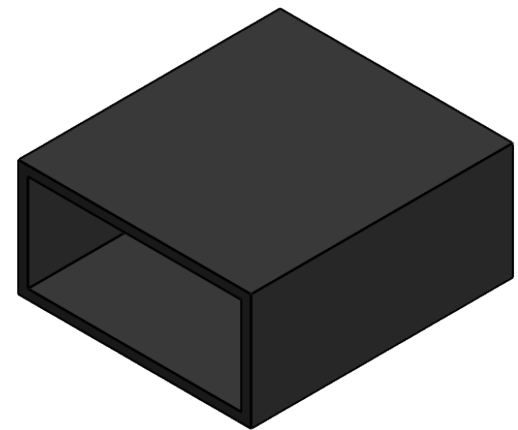
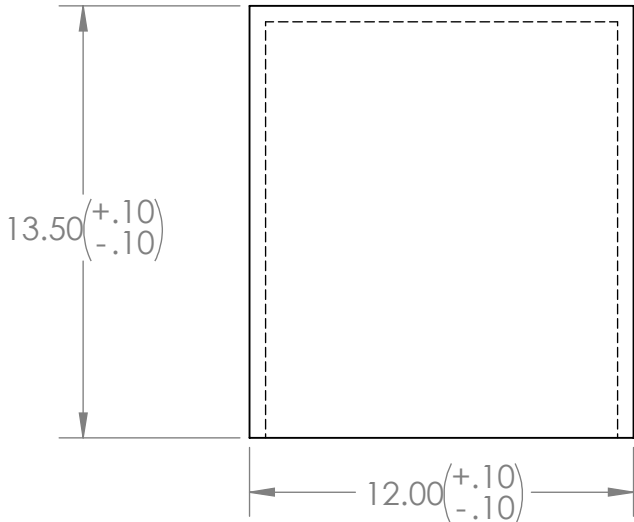

A

A

PROPRIETARY AND CONFIDENTIAL
 THE INFORMATION CONTAINED IN THIS DRAWING IS THE SOLE PROPERTY OF <INSERT COMPANY NAME HERE>. ANY REPRODUCTION IN PART OR AS A WHOLE WITHOUT THE WRITTEN PERMISSION OF <INSERT COMPANY NAME HERE> IS PROHIBITED.

		UNLESS OTHERWISE SPECIFIED:		NAME	DATE
		DIMENSIONS ARE IN INCHES	DRAWN	Kenyon	
		TOLERANCES:	CHECKED		
		FRACTIONAL ±	ENG APPR.		
		ANGULAR: MACH ± BEND ±	MFG APPR.		
		TWO PLACE DECIMAL ±	Q.A.		
		THREE PLACE DECIMAL ±	COMMENTS:		
		INTERPRET GEOMETRIC TOLERANCING PER:			
		MATERIAL			
		BC Plywood			
		FINISH			
NEXT ASSY	USED ON				
APPLICATION		DO NOT SCALE DRAWING			

TITLE:		
Storage_ASM		
SIZE	DWG. NO.	REV
A	Drawer_Housing	
SCALE: 1:5	WEIGHT:	SHEET 13 OF 22

2

1

2

1

B

B

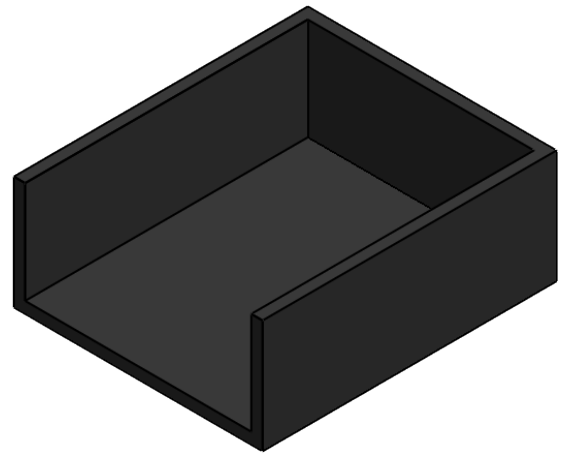
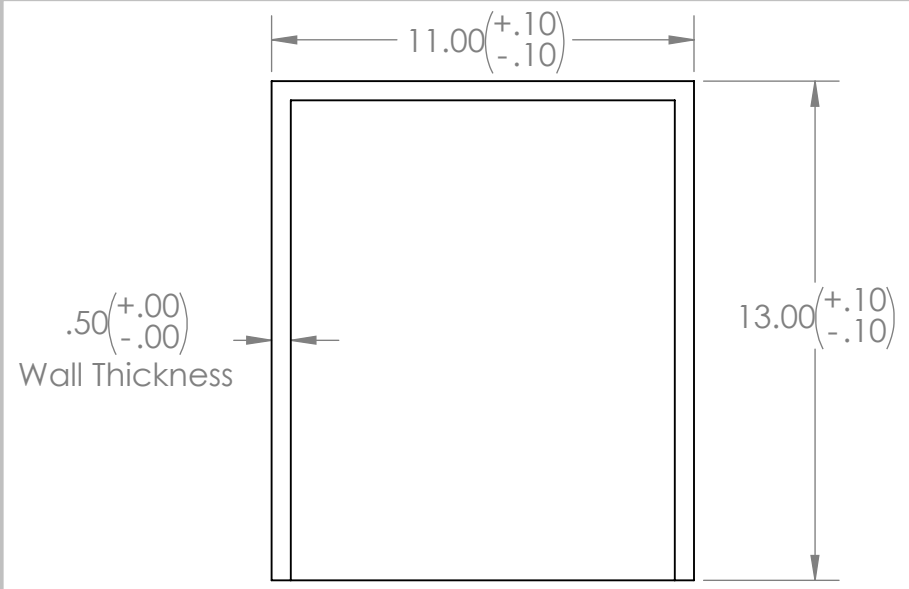

A

A

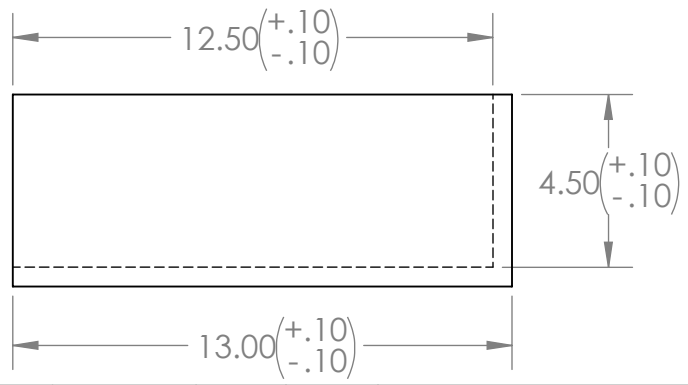
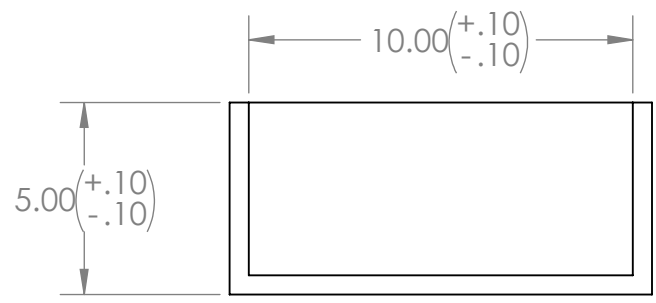

PROPRIETARY AND CONFIDENTIAL
 THE INFORMATION CONTAINED IN THIS DRAWING IS THE SOLE PROPERTY OF <INSERT COMPANY NAME HERE>. ANY REPRODUCTION IN PART OR AS A WHOLE WITHOUT THE WRITTEN PERMISSION OF <INSERT COMPANY NAME HERE> IS PROHIBITED.

		UNLESS OTHERWISE SPECIFIED:		NAME	DATE
		DIMENSIONS ARE IN INCHES	DRAWN	Kenyon	
		TOLERANCES:	CHECKED		
		FRACTIONAL ±	ENG APPR.		
		ANGULAR: MACH ± BEND ±	MFG APPR.		
		TWO PLACE DECIMAL ±	Q.A.		
		THREE PLACE DECIMAL ±	COMMENTS:		
		INTERPRET GEOMETRIC TOLERANCING PER:			
		MATERIAL			
		BC Plywood			
NEXT ASSY	USED ON	FINISH			
	APPLICATION	DO NOT SCALE DRAWING			

TITLE:		
Storage_ASM		
SIZE	DWG. NO.	REV
A	Drawer_Main	
SCALE: 1:5	WEIGHT:	SHEET 14 OF 22

2

1

2

1

B

B

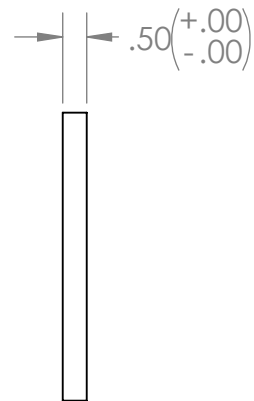
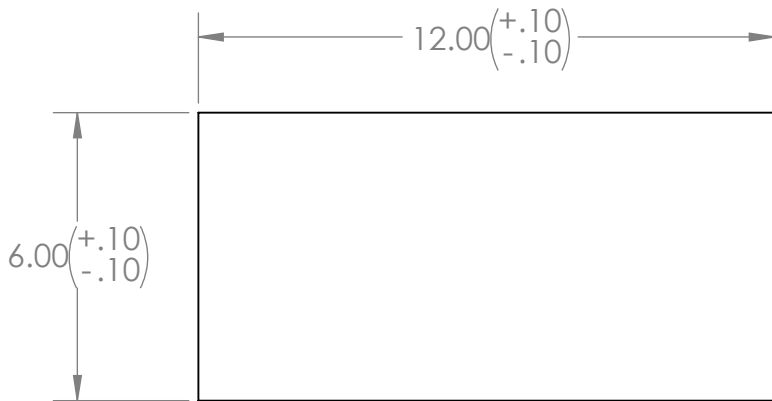
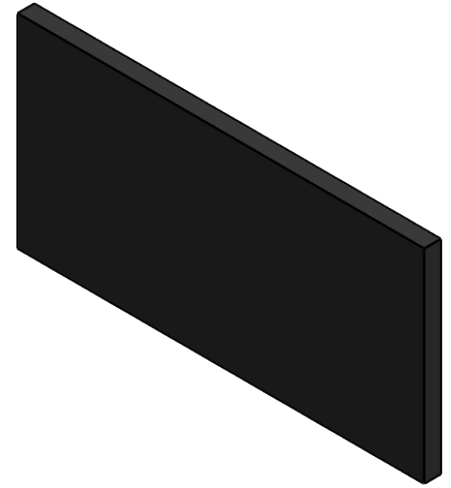
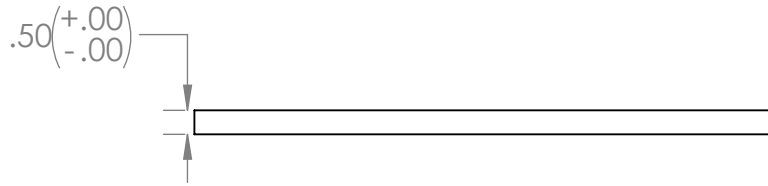

A

A

PROPRIETARY AND CONFIDENTIAL
 THE INFORMATION CONTAINED IN THIS DRAWING IS THE SOLE PROPERTY OF <INSERT COMPANY NAME HERE>. ANY REPRODUCTION IN PART OR AS A WHOLE WITHOUT THE WRITTEN PERMISSION OF <INSERT COMPANY NAME HERE> IS PROHIBITED.

		UNLESS OTHERWISE SPECIFIED:		NAME	DATE
		DIMENSIONS ARE IN INCHES	DRAWN	Kenyon	
		TOLERANCES:	CHECKED		
		FRACTIONAL ±	ENG APPR.		
		ANGULAR: MACH ± BEND ±	MFG APPR.		
		TWO PLACE DECIMAL ±	Q.A.		
		THREE PLACE DECIMAL ±	COMMENTS:		
		INTERPRET GEOMETRIC TOLERANCING PER:			
		MATERIAL			
		BC Plywood			
		FINISH			
NEXT ASSY	USED ON				
APPLICATION		DO NOT SCALE DRAWING			

TITLE:		
Storage_ASM		
SIZE	DWG. NO.	REV
A	Front_Plate	
SCALE: 1:5	WEIGHT:	SHEET 15 OF 22

2

1

2

1

B

B

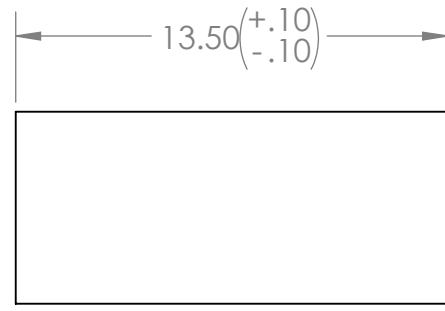
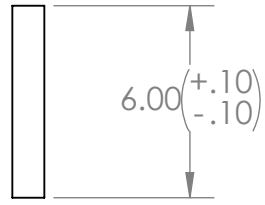
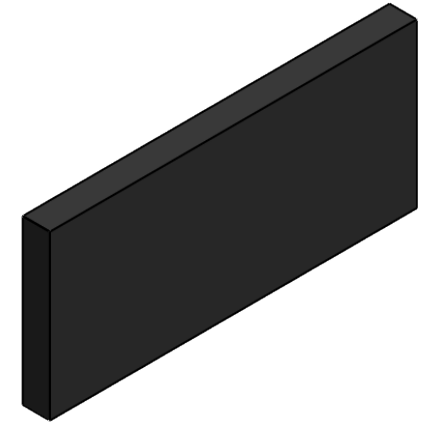
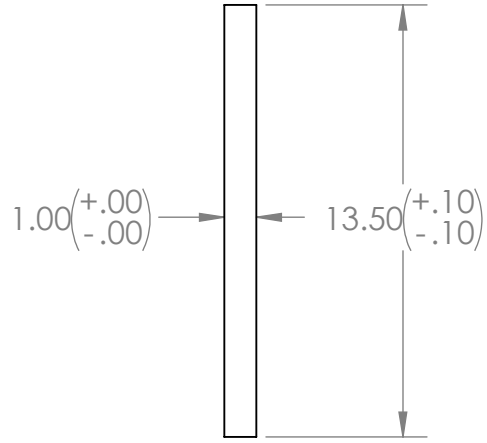

A

A

PROPRIETARY AND CONFIDENTIAL
 THE INFORMATION CONTAINED IN THIS DRAWING IS THE SOLE PROPERTY OF <INSERT COMPANY NAME HERE>. ANY REPRODUCTION IN PART OR AS A WHOLE WITHOUT THE WRITTEN PERMISSION OF <INSERT COMPANY NAME HERE> IS PROHIBITED.

		UNLESS OTHERWISE SPECIFIED:		NAME	DATE
		DIMENSIONS ARE IN INCHES	DRAWN	Kenyon	
		TOLERANCES:	CHECKED		
		FRACTIONAL ±	ENG APPR.		
		ANGULAR: MACH ± BEND ±	MFG APPR.		
		TWO PLACE DECIMAL ±	Q.A.		
		THREE PLACE DECIMAL ±	COMMENTS:		
		INTERPRET GEOMETRIC TOLERANCING PER:			
		MATERIAL			
		BC Plywood			
		FINISH			
NEXT ASSY	USED ON				
APPLICATION		DO NOT SCALE DRAWING			

TITLE:		
Storage_ASM		
SIZE	DWG. NO.	REV
A	Drawer_Support	
SCALE: 1:5	WEIGHT:	SHEET 16 OF 22

2

1

2

1

B

B

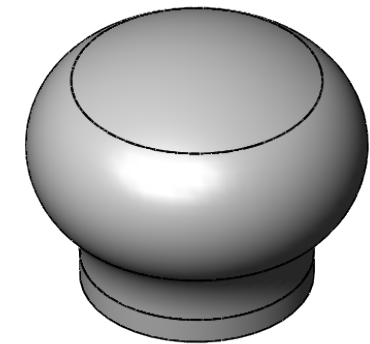
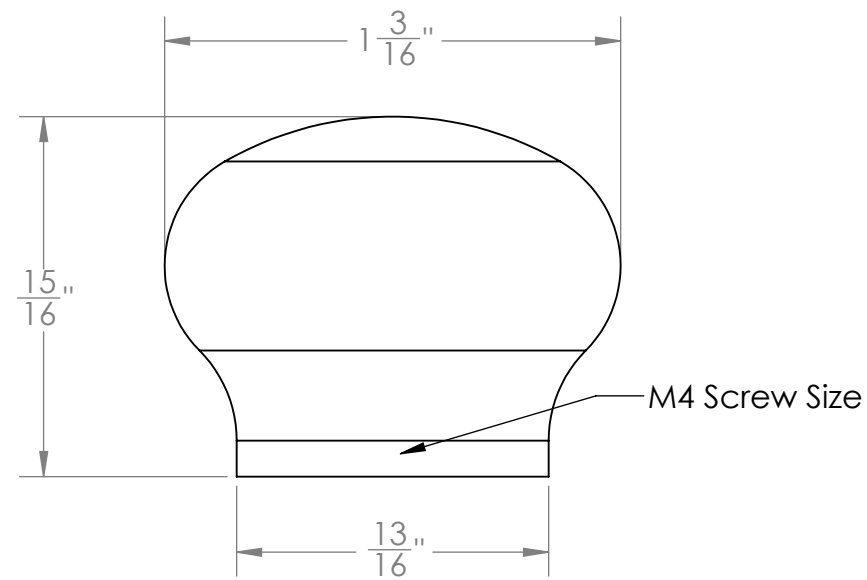

A

A

PROPRIETARY AND CONFIDENTIAL
 THE INFORMATION CONTAINED IN THIS DRAWING IS THE SOLE PROPERTY OF <INSERT COMPANY NAME HERE>. ANY REPRODUCTION IN PART OR AS A WHOLE WITHOUT THE WRITTEN PERMISSION OF <INSERT COMPANY NAME HERE> IS PROHIBITED.

		UNLESS OTHERWISE SPECIFIED:		NAME	DATE
		DIMENSIONS ARE IN INCHES	DRAWN	Kenyon	
		TOLERANCES:	CHECKED		
		FRACTIONAL \pm	ENG APPR.		
		ANGULAR: MACH \pm BEND \pm	MFG APPR.		
		TWO PLACE DECIMAL \pm	Q.A.		
		THREE PLACE DECIMAL \pm	COMMENTS:	Part from McMaster-Carr.	
		INTERPRET GEOMETRIC TOLERANCING PER:			
		MATERIAL			
		FINISH			
NEXT ASSY	USED ON				
APPLICATION		DO NOT SCALE DRAWING			

TITLE:
Storage_ASM

SIZE	DWG. NO.	REV
A	Drawer_Knob	
SCALE: 2:1	WEIGHT:	SHEET 17 OF 22

2

1

2

1

B

B

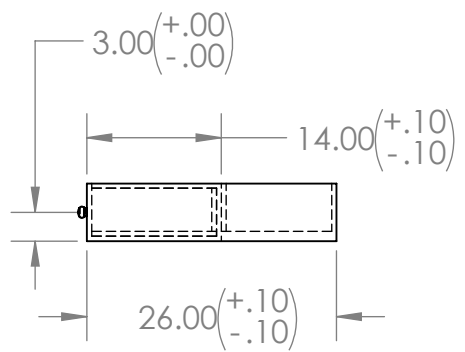
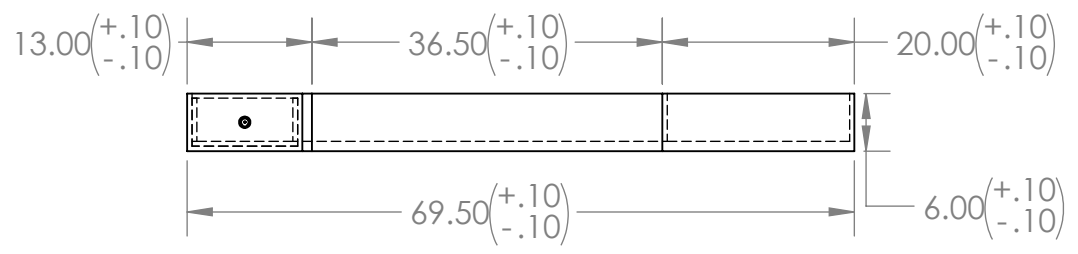
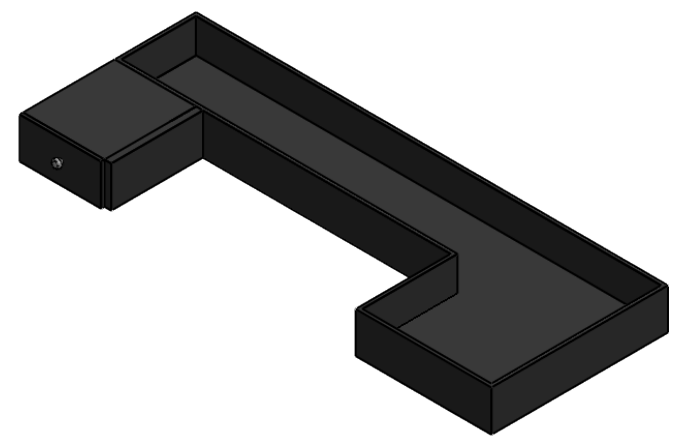
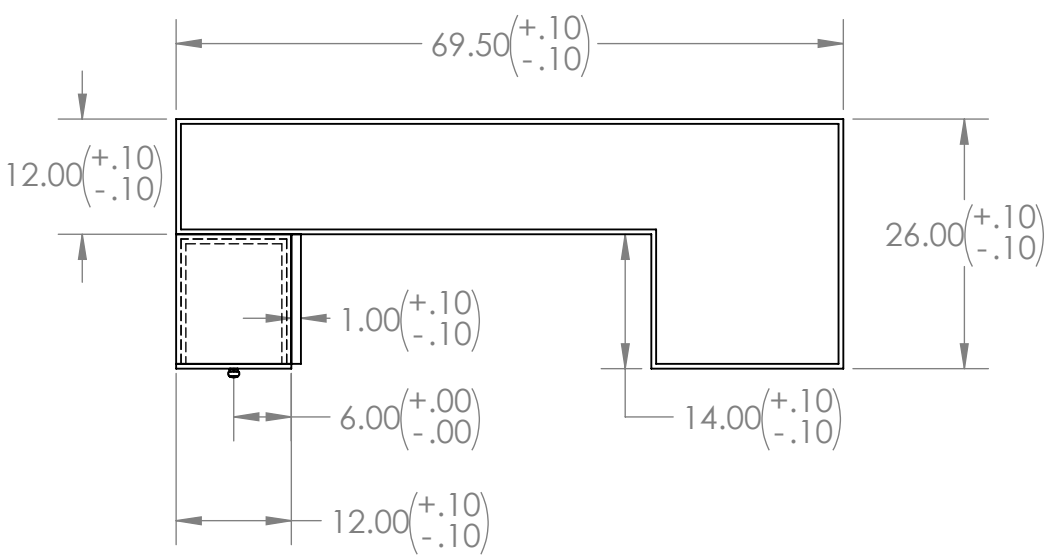

A

A

PROPRIETARY AND CONFIDENTIAL
 THE INFORMATION CONTAINED IN THIS DRAWING IS THE SOLE PROPERTY OF <INSERT COMPANY NAME HERE>. ANY REPRODUCTION IN PART OR AS A WHOLE WITHOUT THE WRITTEN PERMISSION OF <INSERT COMPANY NAME HERE> IS PROHIBITED.

		UNLESS OTHERWISE SPECIFIED:	NAME	DATE
		DIMENSIONS ARE IN INCHES	DRAWN	Kenyon
		TOLERANCES:	CHECKED	
		FRACTIONAL ±	ENG APPR.	
		ANGULAR: MACH ± BEND ±	MFG APPR.	
		TWO PLACE DECIMAL ±	Q.A.	
		THREE PLACE DECIMAL ±	COMMENTS:	
		INTERPRET GEOMETRIC TOLERANCING PER:		
		MATERIAL		
		FINISH		
NEXT ASSY	USED ON			
APPLICATION		DO NOT SCALE DRAWING		

TITLE:		
Storage_ASM		
SIZE	DWG. NO.	REV
A	Storage_Full	
SCALE: 1:20		WEIGHT:
		SHEET 18 OF 22

2

1

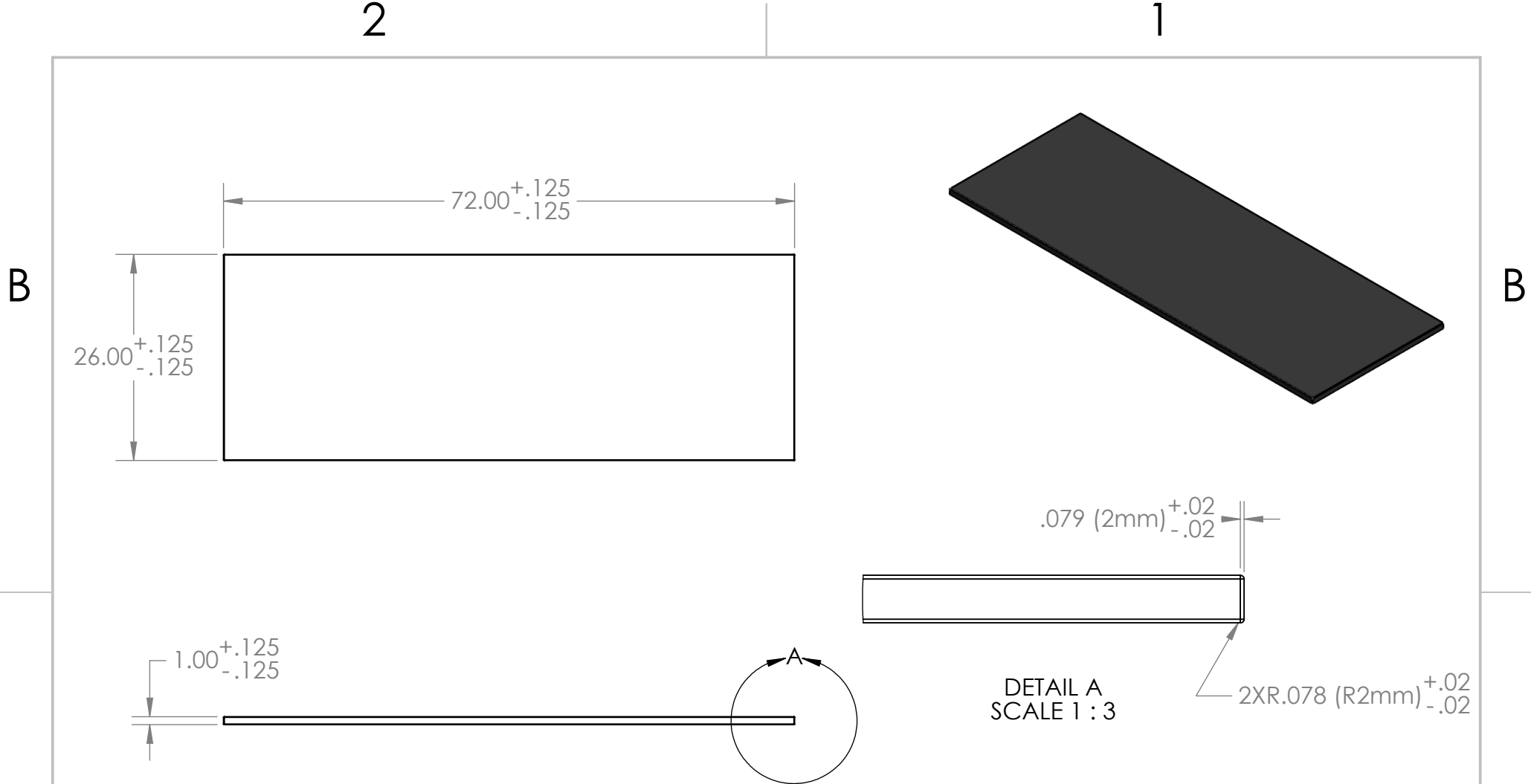

<p>PROPRIETARY AND CONFIDENTIAL THE INFORMATION CONTAINED IN THIS DRAWING IS THE SOLE PROPERTY OF <INSERT COMPANY NAME HERE>. ANY REPRODUCTION IN PART OR AS A WHOLE WITHOUT THE WRITTEN PERMISSION OF <INSERT COMPANY NAME HERE> IS PROHIBITED.</p>			UNLESS OTHERWISE SPECIFIED:		NAME	DATE	<p>TITLE: Tabletop_ASM</p>
			DIMENSIONS ARE IN INCHES	DRAWN	Kenyon		
			TOLERANCES:	CHECKED			
			FRACTIONAL ±	ENG APPR.			
			ANGULAR: MACH ± BEND ±	MFG APPR.			
		TWO PLACE DECIMAL ±	Q.A.				
		THREE PLACE DECIMAL ±	INTERPRET GEOMETRIC TOLERANCING PER:	COMMENTS:			
			MATERIAL	Part			SIZE
			Wilsonart	Manufactured by			DWG. NO.
			FINISH	Only Table Tops			REV
	NEXT ASSY	USED ON					
	APPLICATION		DO NOT SCALE DRAWING				SCALE: 1:20 WEIGHT: SHEET 19 OF 22

B

B

2

1

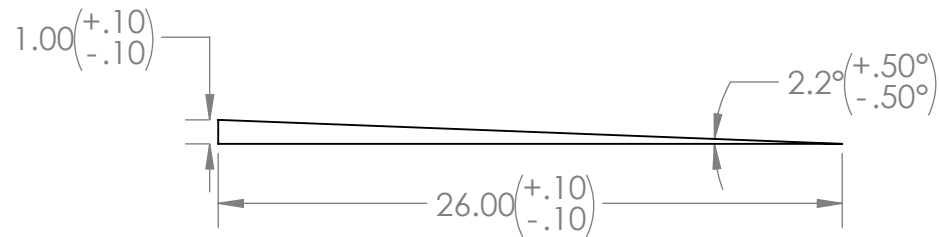
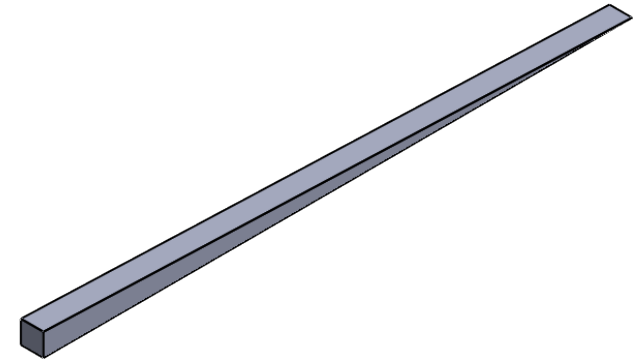
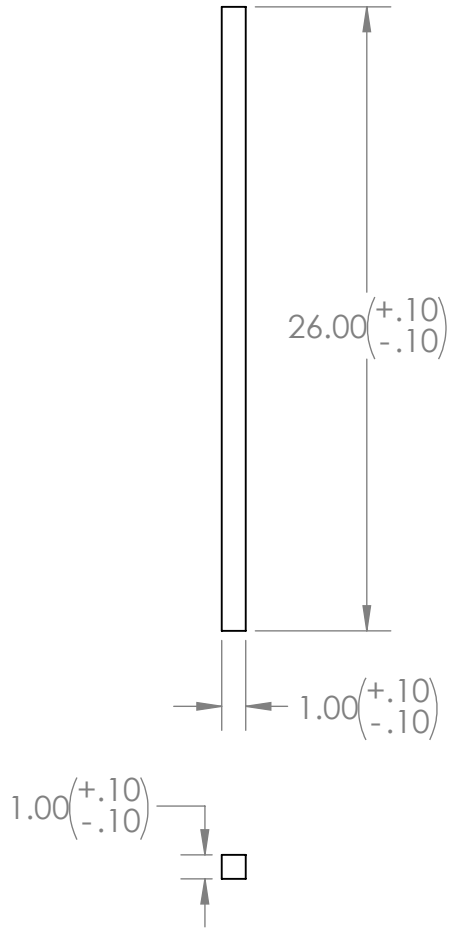

A

A

PROPRIETARY AND CONFIDENTIAL
 THE INFORMATION CONTAINED IN THIS DRAWING IS THE SOLE PROPERTY OF <INSERT COMPANY NAME HERE>. ANY REPRODUCTION IN PART OR AS A WHOLE WITHOUT THE WRITTEN PERMISSION OF <INSERT COMPANY NAME HERE> IS PROHIBITED.

		UNLESS OTHERWISE SPECIFIED:		NAME	DATE
		DIMENSIONS ARE IN INCHES	DRAWN	Kenyon	
		TOLERANCES:	CHECKED		
		FRACTIONAL ±	ENG APPR.		
		ANGULAR: MACH ± BEND ±	MFG APPR.		
		TWO PLACE DECIMAL ±	Q.A.		
		THREE PLACE DECIMAL ±	COMMENTS:		
		INTERPRET GEOMETRIC TOLERANCING PER:			
		MATERIAL			
		Mild Steel			
		FINISH			
NEXT ASSY	USED ON				
APPLICATION		DO NOT SCALE DRAWING			

TITLE:
Tabletop_ASM

SIZE DWG. NO. REV
A Wedge

SCALE: 1:10 WEIGHT: SHEET 20 OF 22

2

1

2

1

B

B

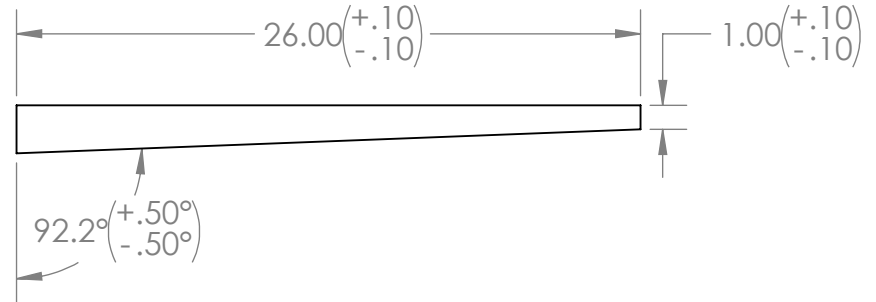
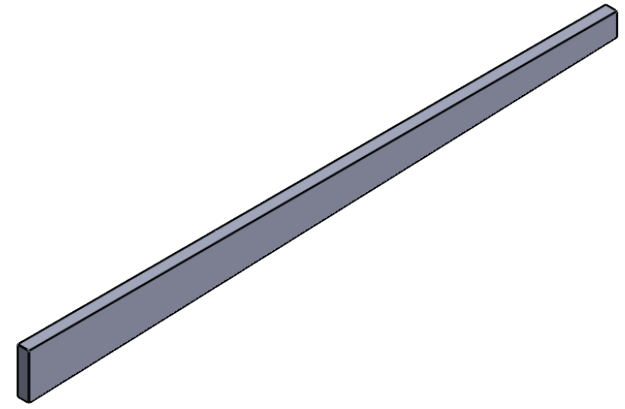
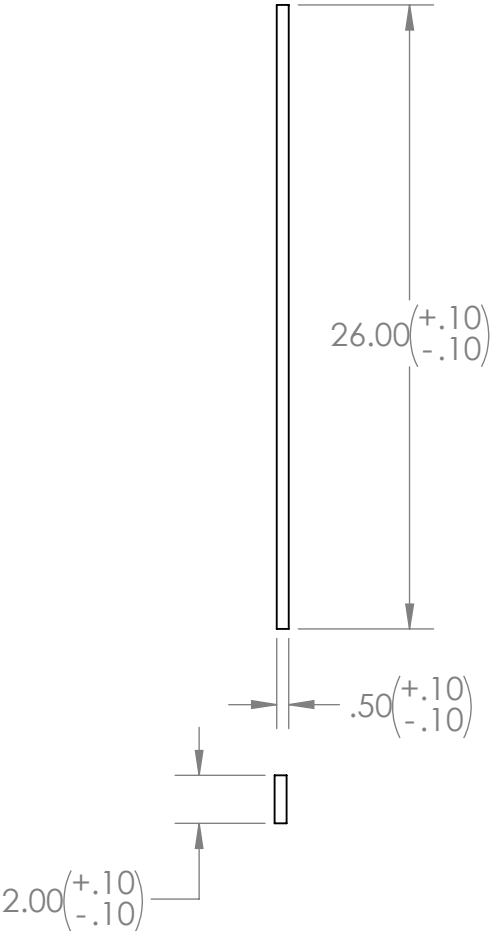

A

A

PROPRIETARY AND CONFIDENTIAL
 THE INFORMATION CONTAINED IN THIS DRAWING IS THE SOLE PROPERTY OF <INSERT COMPANY NAME HERE>. ANY REPRODUCTION IN PART OR AS A WHOLE WITHOUT THE WRITTEN PERMISSION OF <INSERT COMPANY NAME HERE> IS PROHIBITED.

		UNLESS OTHERWISE SPECIFIED:		NAME	DATE
		DIMENSIONS ARE IN INCHES	DRAWN	Kenyon	
		TOLERANCES:	CHECKED		
		FRACTIONAL ±	ENG APPR.		
		ANGULAR: MACH ± BEND ±	MFG APPR.		
		TWO PLACE DECIMAL ±	Q.A.		
		THREE PLACE DECIMAL ±	COMMENTS:		
		INTERPRET GEOMETRIC TOLERANCING PER:			
		MATERIAL			
		Mild Steel			
		FINISH			
NEXT ASSY	USED ON				
APPLICATION		DO NOT SCALE DRAWING			

TITLE:		
Tabletop_ASM		
SIZE	DWG. NO.	REV
A	Wedge_Groove	
SCALE: 1:10	WEIGHT:	SHEET 21 OF 22

2

1

2

1

B

B

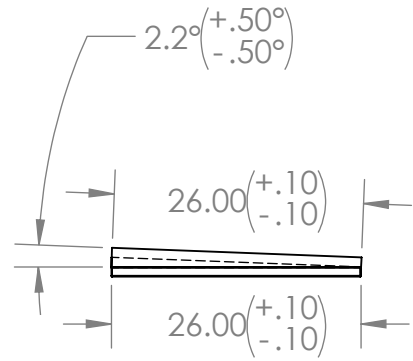
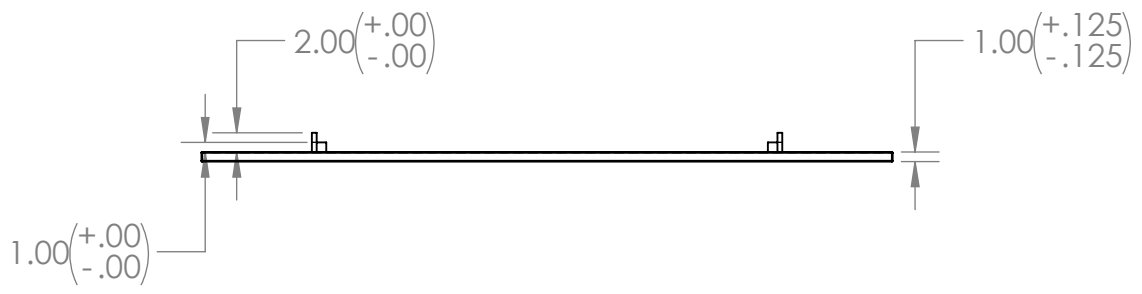
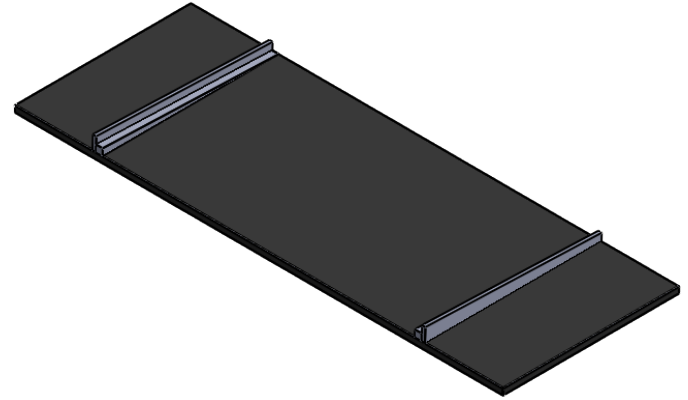
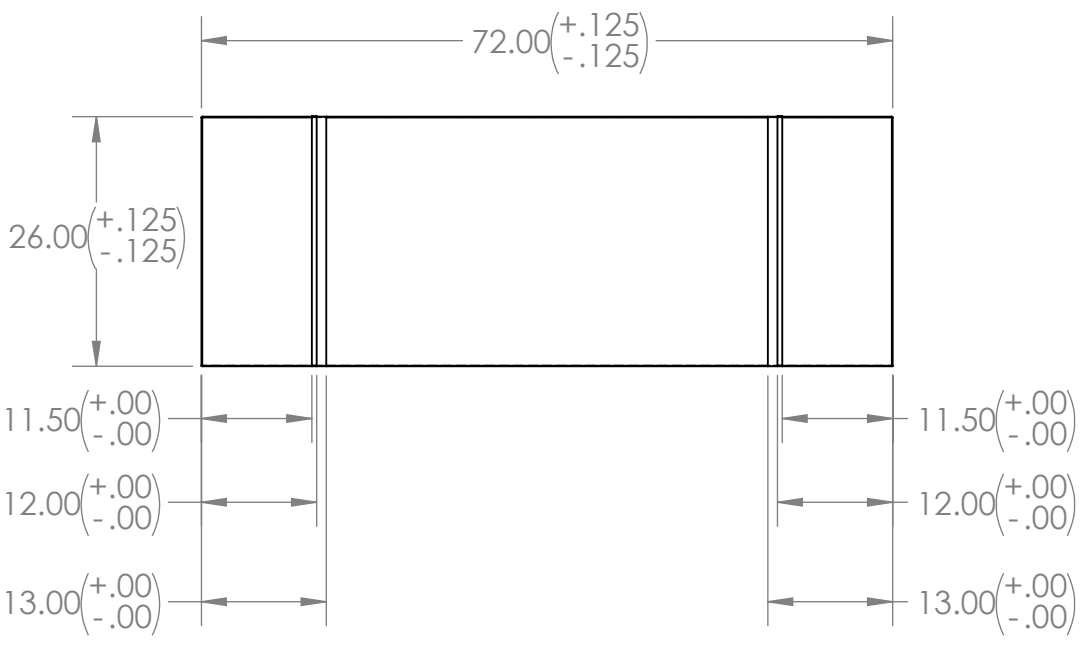

A

A

PROPRIETARY AND CONFIDENTIAL
 THE INFORMATION CONTAINED IN THIS DRAWING IS THE SOLE PROPERTY OF <INSERT COMPANY NAME HERE>. ANY REPRODUCTION IN PART OR AS A WHOLE WITHOUT THE WRITTEN PERMISSION OF <INSERT COMPANY NAME HERE> IS PROHIBITED.

		UNLESS OTHERWISE SPECIFIED:	NAME	DATE
		DIMENSIONS ARE IN INCHES	DRAWN	Kenyon
		TOLERANCES:	CHECKED	
		FRACTIONAL \pm	ENG APPR.	
		ANGULAR: MACH \pm BEND \pm	MFG APPR.	
		TWO PLACE DECIMAL \pm	Q.A.	
		THREE PLACE DECIMAL \pm	COMMENTS:	
		INTERPRET GEOMETRIC TOLERANCING PER:		
		MATERIAL		
		FINISH		
NEXT ASSY	USED ON			
APPLICATION		DO NOT SCALE DRAWING		

TITLE:		
Tabletop_ASM		
SIZE	DWG. NO.	REV
A	Tabletop_Full	
SCALE: 1:20		WEIGHT:
		SHEET 22 OF 22

2

1