

Hozhoni Foundation  
Button Maker  
Final presentation  
28/04/2017  
Team#26

Abdullah Alajmi - ( project manager. )

● Majid Alenezi - ( secretary/ document ) manager.

Mutlaq Alajmi - (website developer. )

Faleh Alajmi -( budget liaison )

# Client's information



- Hozhoni foundation company
- It's a leading provider of services for people with disabilities
- Our client is Dr. Sarah Oman



# Project Description:

- The goal of this project is to create a device that cuts six buttons at once.
- The product is directed towards people with disabilities who need assistance cutting the paper.
- The project is about designing a paper cutting press, with an “ Handle ” as lever.

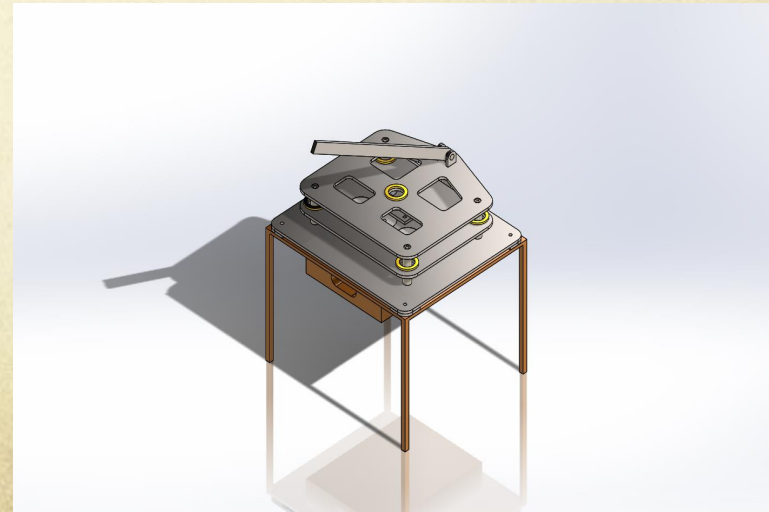

# Customer Requirements:

- smaller than last year's solution
- lighter than last year's solution
- cut out six circle patterns at once
- operational with only one hand/arm
- cut out patterns cleanly with no ripped edges
- guide to position the papers exactly and not let them move during cutting



# Engineering Requirement

- Size of the system
- Minimize weight
- Able to cut multiple pages
- Cut six circle buttons
- Force required to actuate
- Rips in edges less than 0.1”

# Brainstorming:

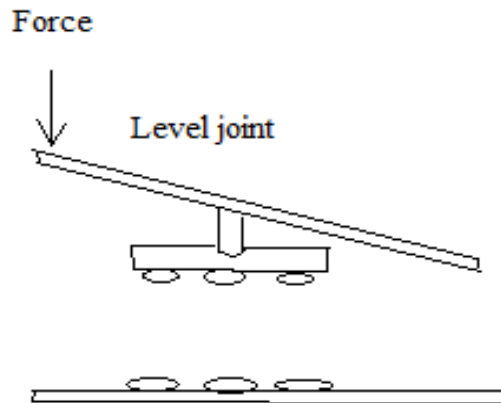
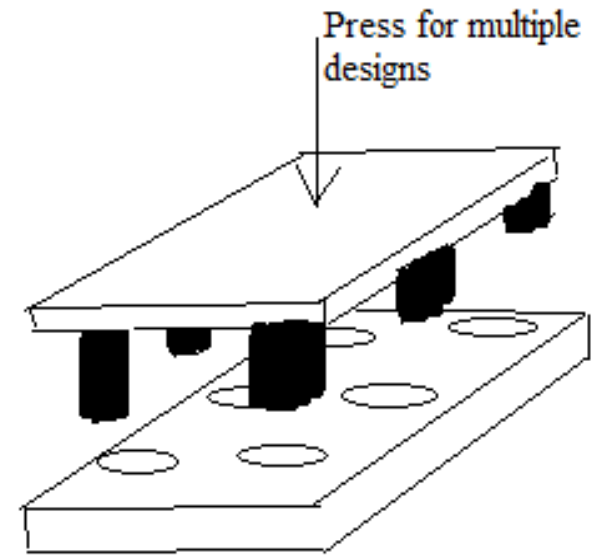
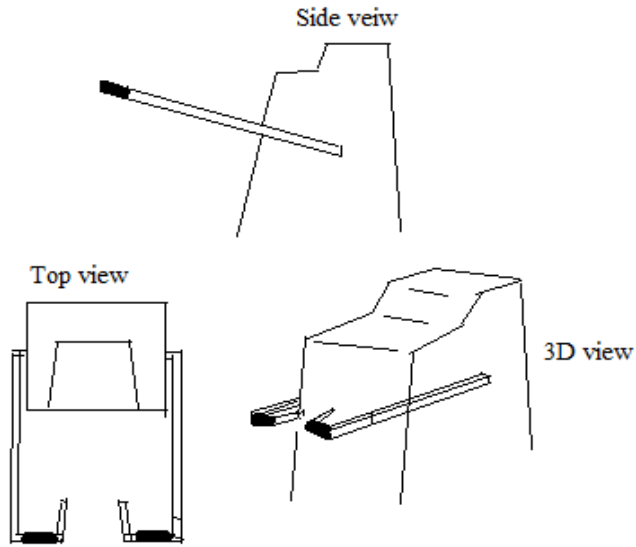

Press plate

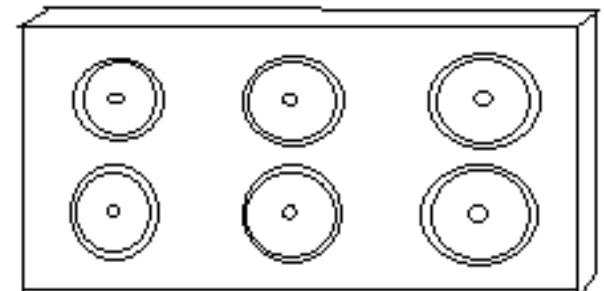

# Top 3 Designs

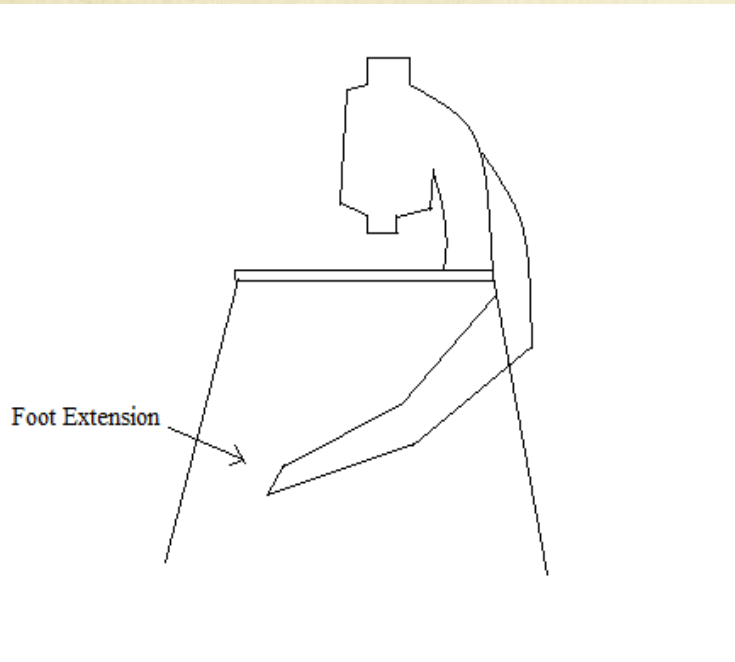

*Foot Extension*

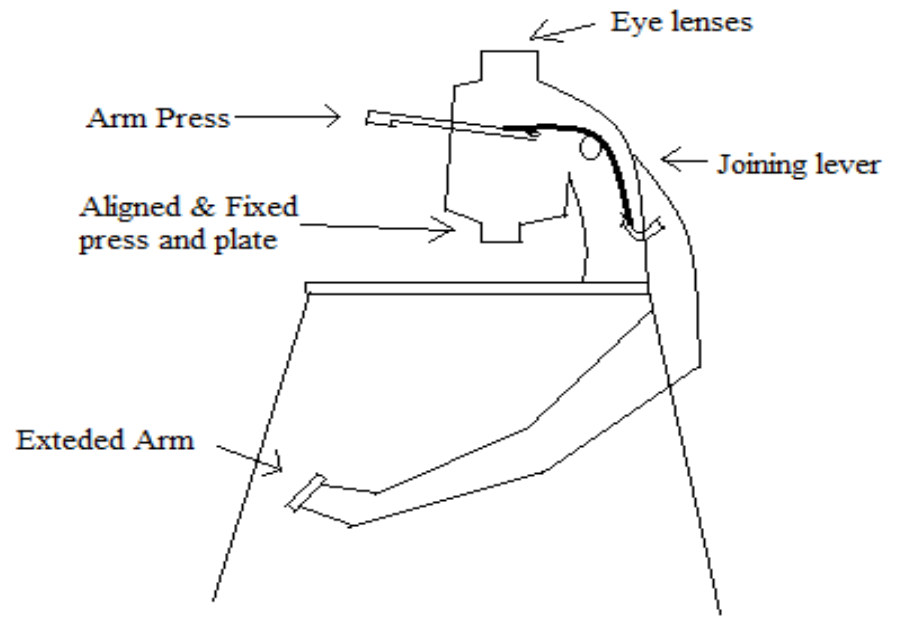

Multiple design

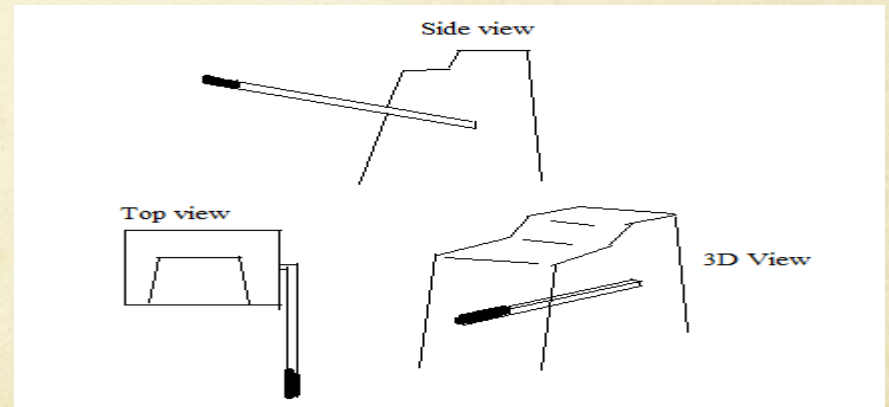

Straight-arm design

# Old Design

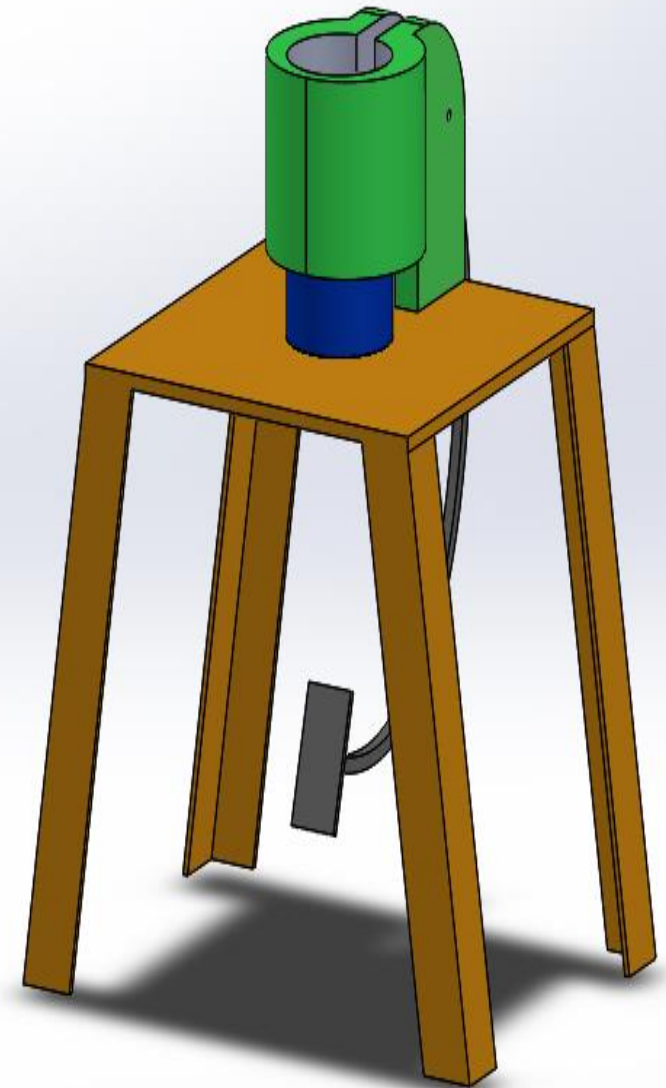
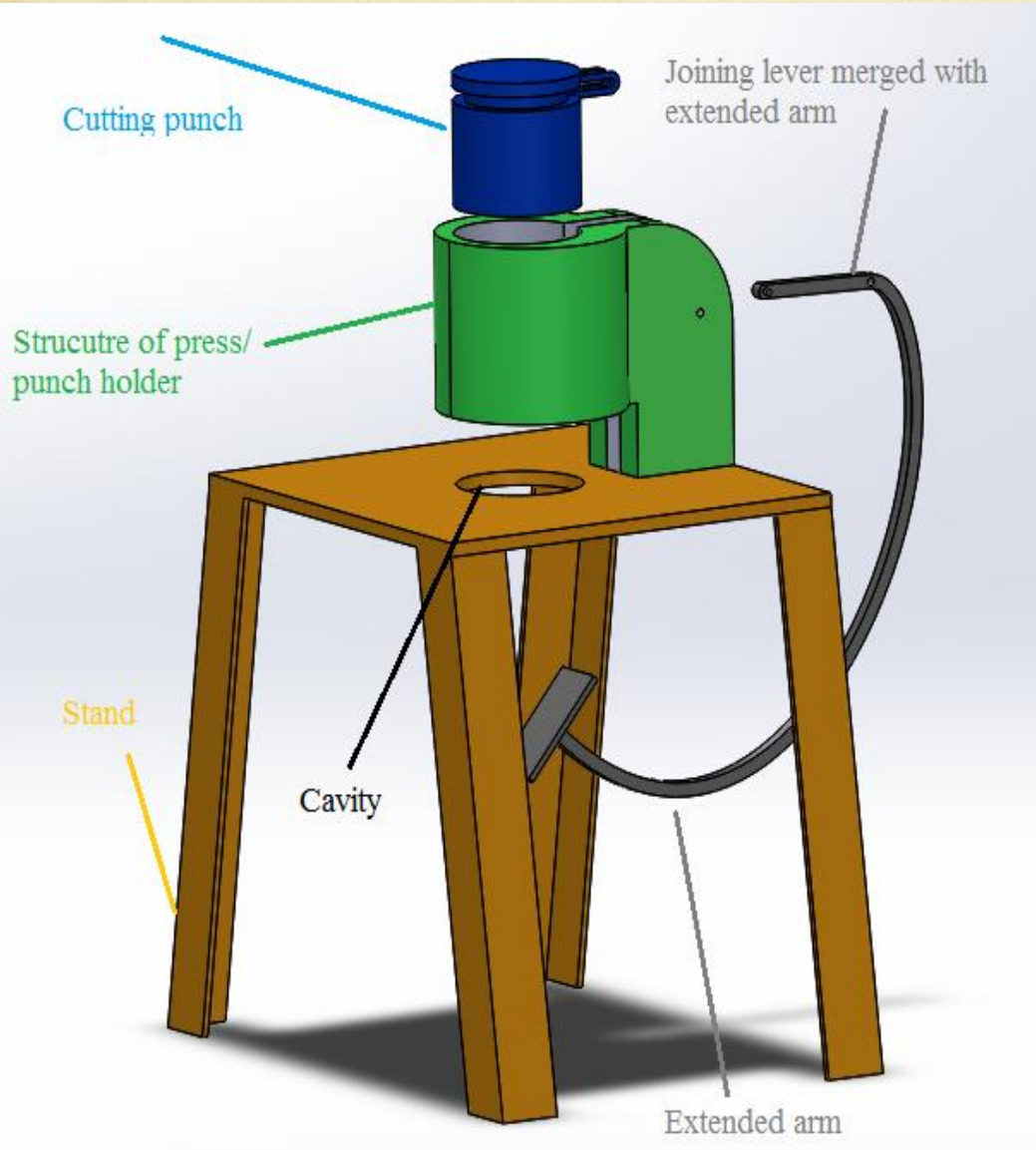



# What was done over the winter break



- Two meetings conducted in Kuwait
- Workshop for brainstorming ideas
- Making plans to improve the project

# New design

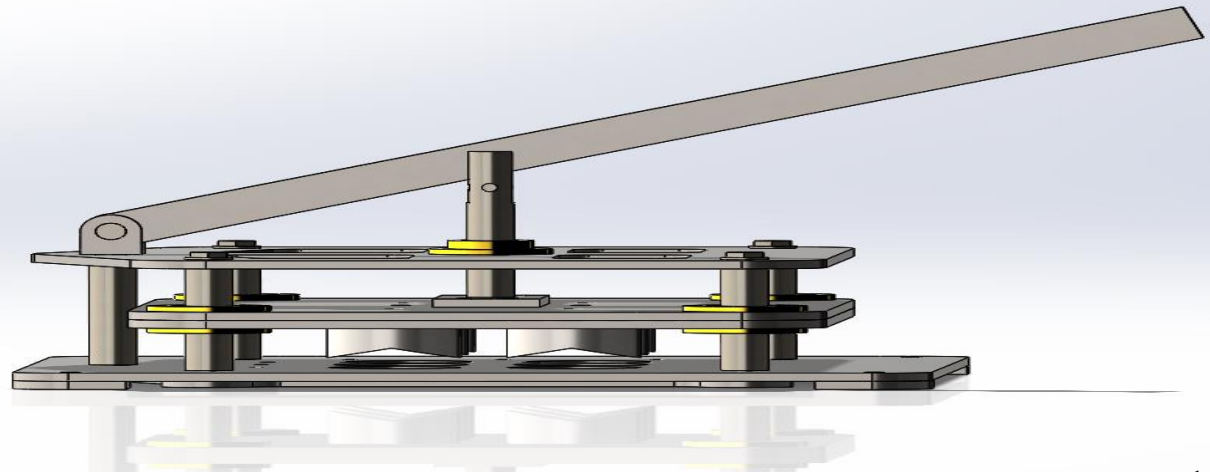
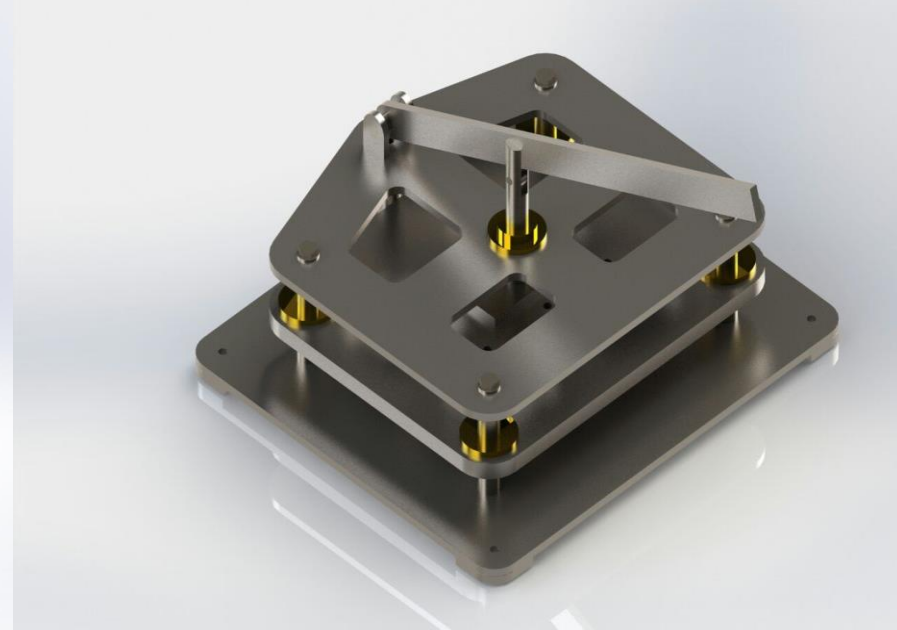
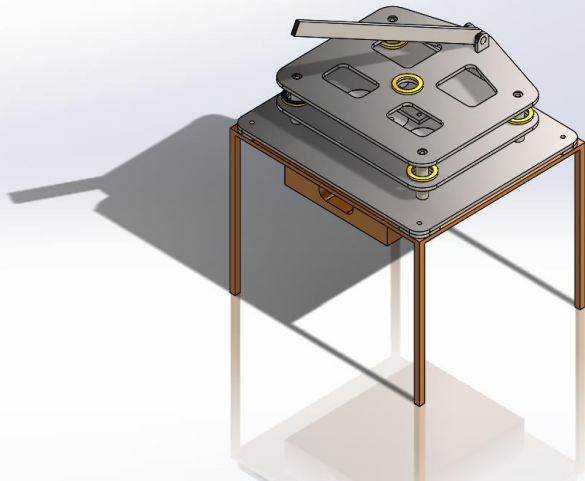

# Compare Between designs

Last year's design

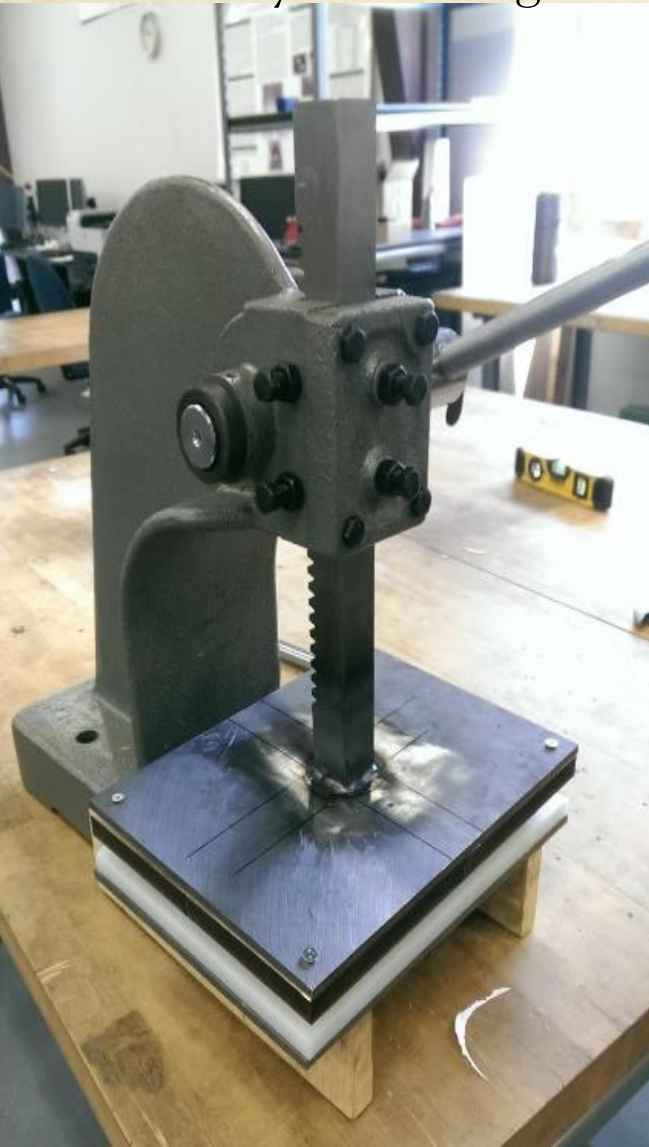

Old design

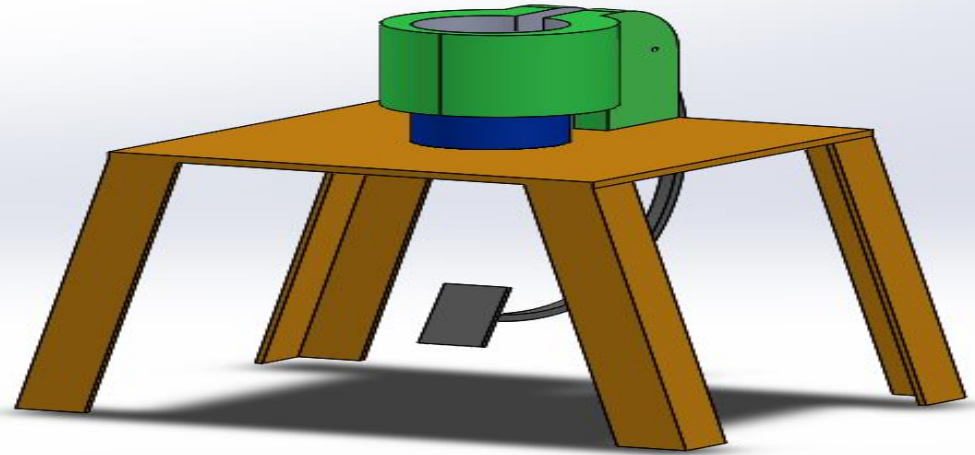

New design

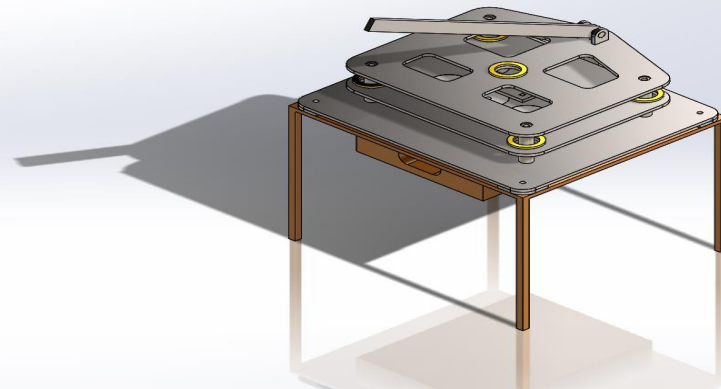

# Video



# Design Solution-Final design

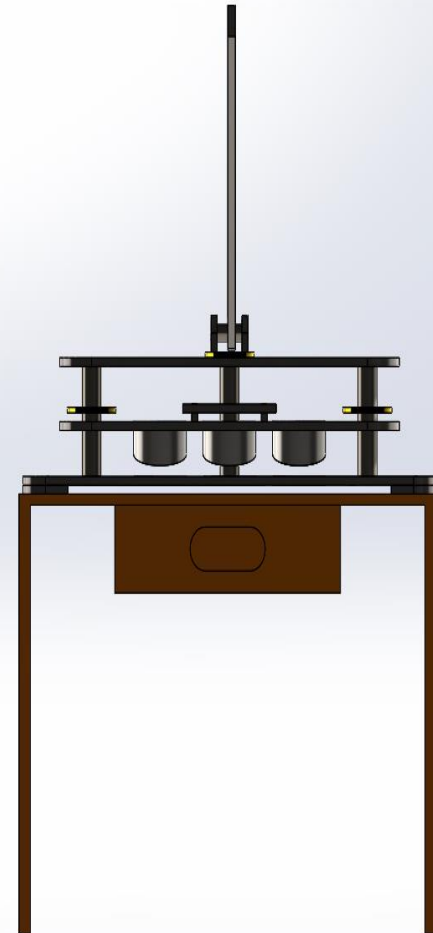

# Manufacturing Process

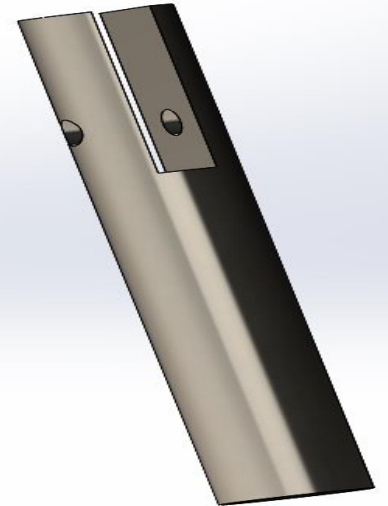
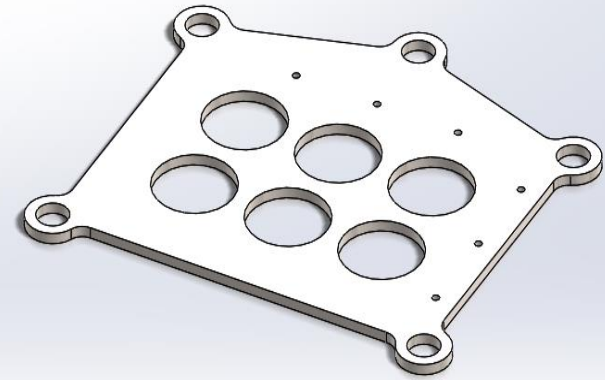
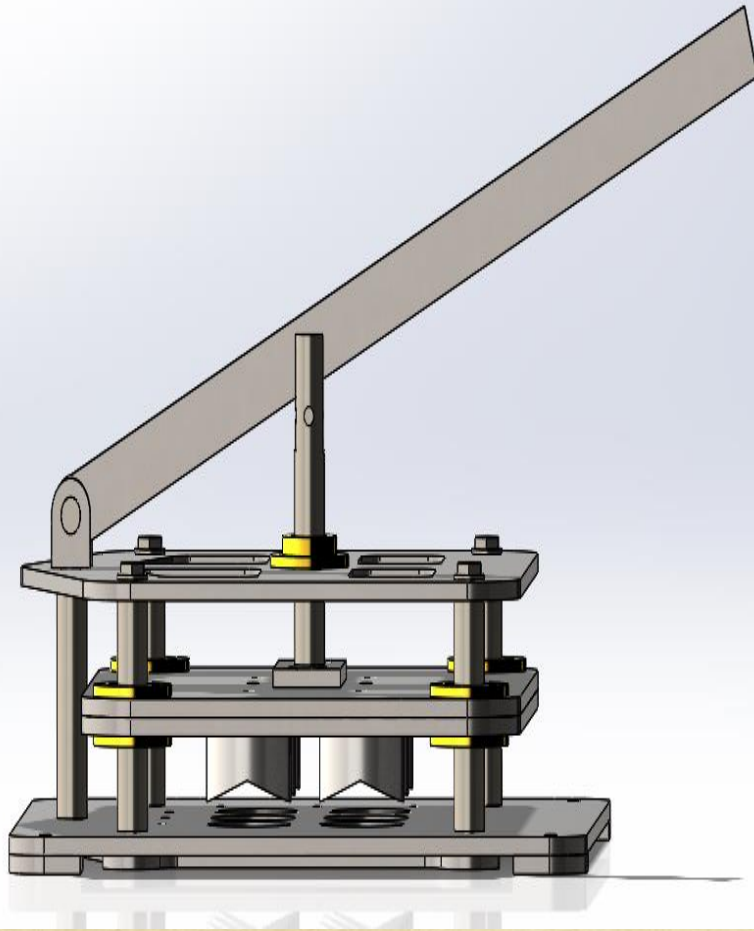

# Manufacturing Process

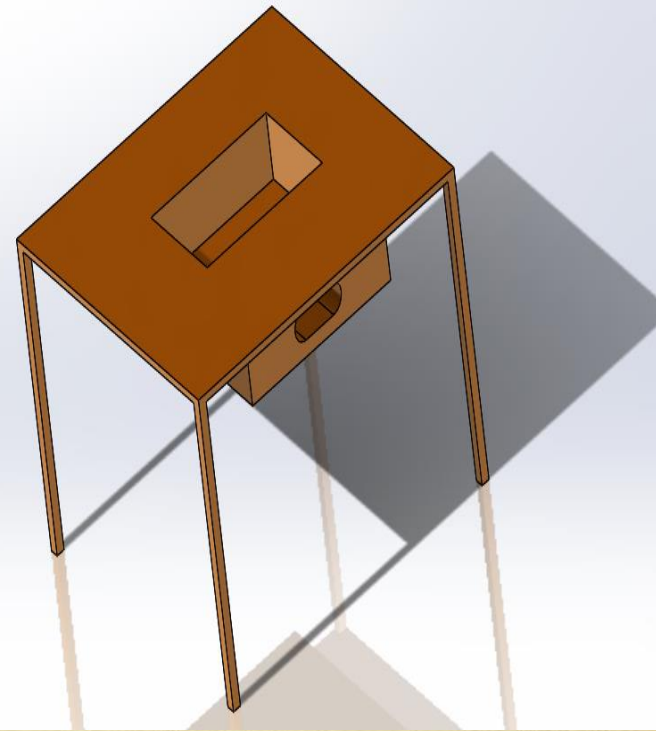
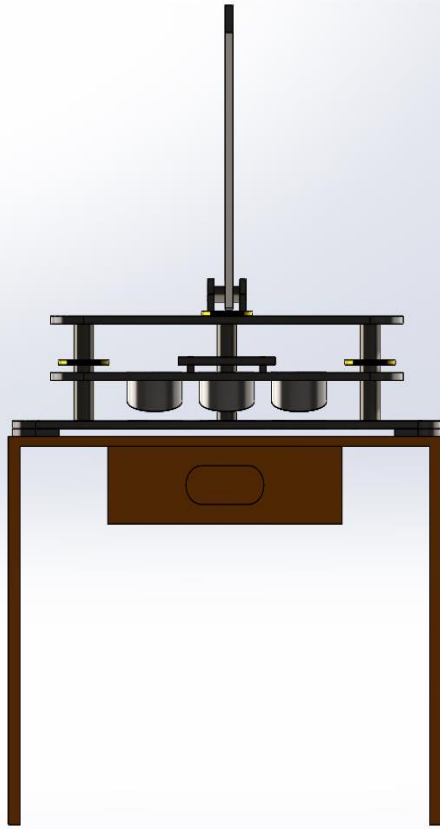

# Manufacturing Process





# Bill of material

Item Number	Item Name	Description	Material	Quantity	Total Cost
1	Base plate	It's a Die of punching Cutters and fixing of slide bars.	Black Steel	1	\$70
2	Top plate	To keep distance between slide bar's fixed and make joint of press arm and guide way.	Black Steel	1	\$70
3	Cutter Holder	To fixe punching Die's	Black Steel	1	\$70
4	Cutter	Treated to be more hard and grinded to accept sharpness for circumference of die	Certified Steel	6	\$450
5	Slide bar's	Bars of steel and coating by Hard chrome layer to increase life time and make very smooth surface for slider's	Hard Chrome Bar	6	\$130
6	Slider's	Hollow bar to slide on chrome bars	Brass	4	\$70
7	Press Arm	To use as hand of press	Black Steel	1	\$30
8	Press Axe	To transfer the force from arm to the holder	Steel	1	\$40
9	Spring's	To restore the holder to initial position	Steel	4	\$20
10	Table	For holding the design not moving	Wood	1	\$100

Total: \$1100

Reaming: \$400

Abdullah Alajmi

# CONCLUSIONS

- Mechanical Advantage is the main perimeter in the modeling of lever and arm mechanisms.
- A careful designed linking system could give us the mechanical advantage of reasonable high values.
- In the future, this proposed design can be modified for further design improvement and automation.

# Acknowledgements

- Dr. Trevas
- Dr. Oman
- TA: Michael Bair

ANY

QUESTIONS

?

